

BuzziPlank

INSTALLATION MANUAL

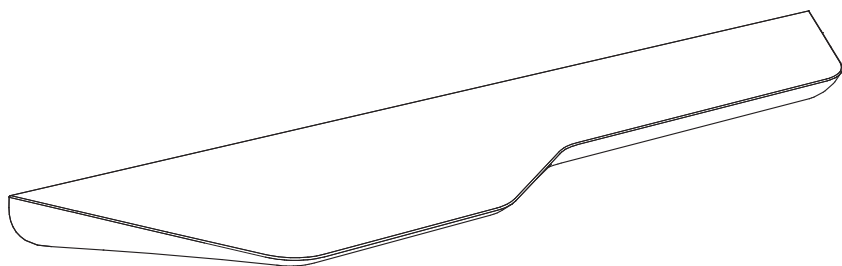

Please note: Due to safety reasons the BuzziPlank should only be mounted by a professional. The max load on the BuzziPlank strongly depends on the mounting structure and the mounting materials used. The BuzziPlank is recommended for mounting on walls made of concrete or brick. Hollow walls have to be reinforced on the backside of the wall. Do use suitable mounting materials.

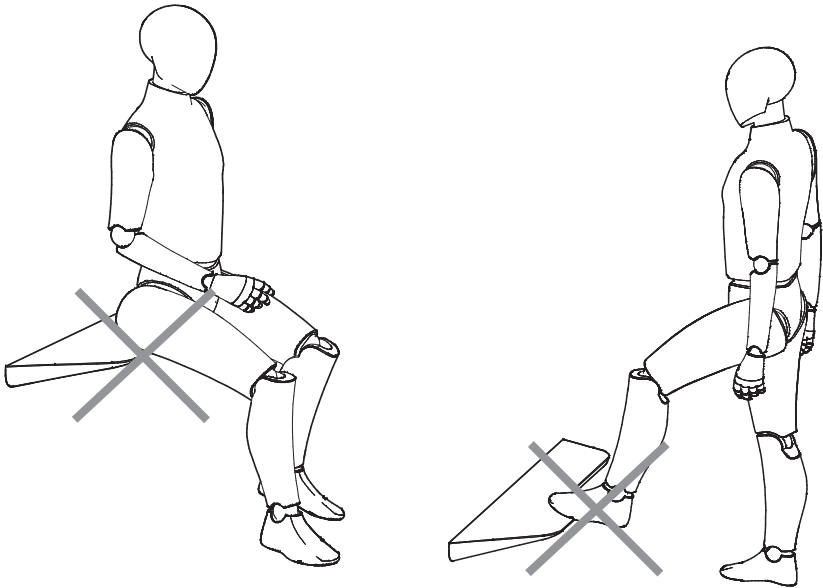
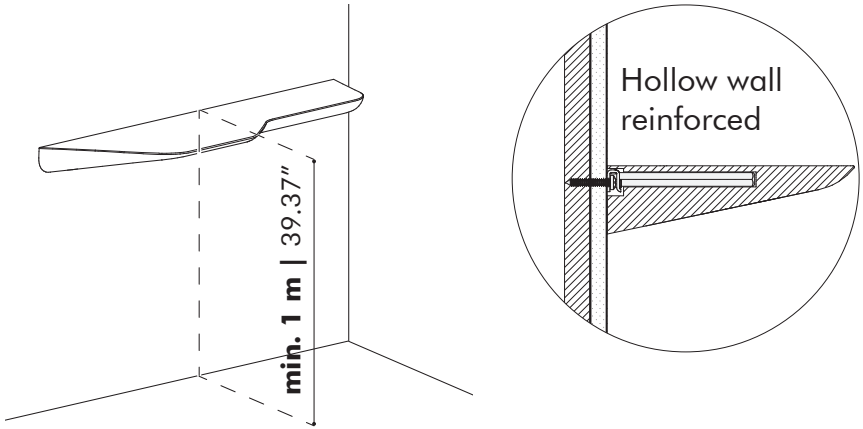

Excluded



4x | 6x



4x | 6x

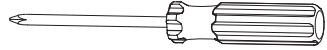
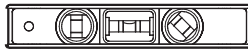
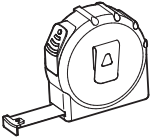
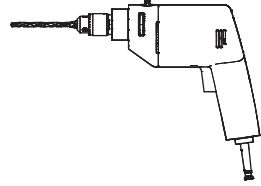
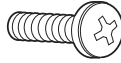

Included BuzziPlank M

2x

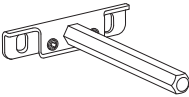

1x

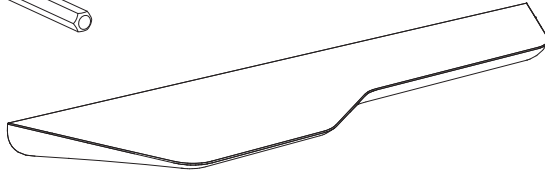
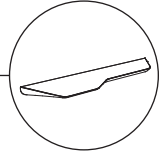

Included BuzziPlank L

3x

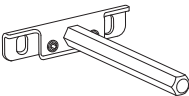

1x

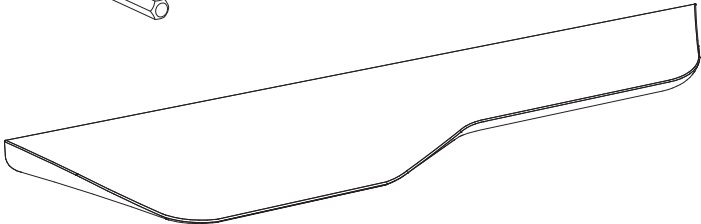
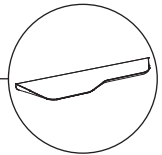

BuzziPlank M|L

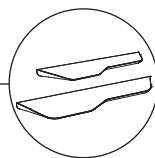

1 PERS.

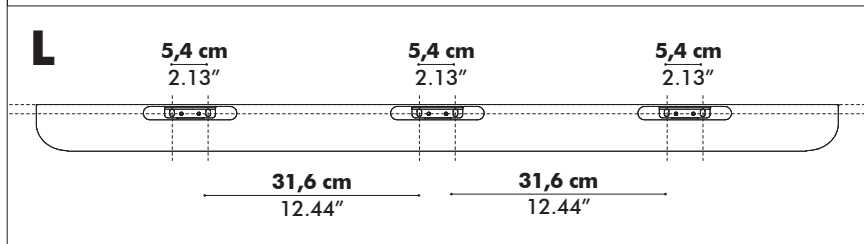
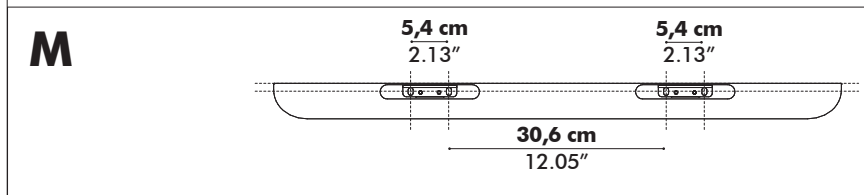
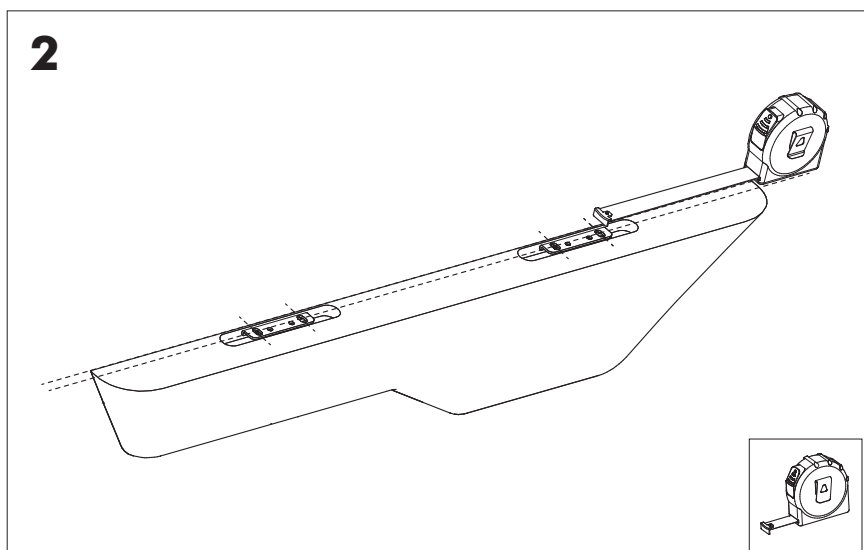
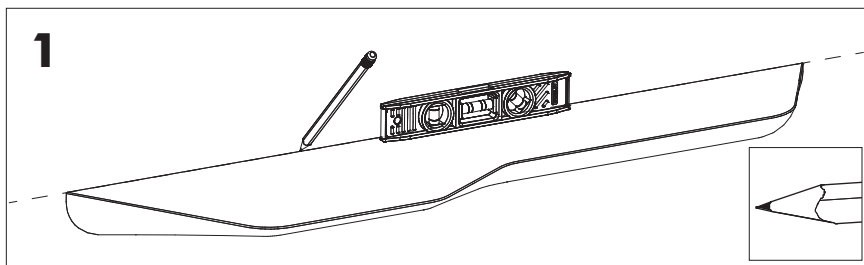

3

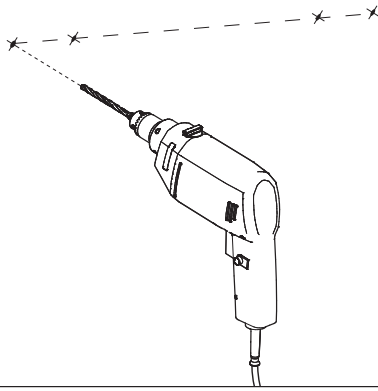

M

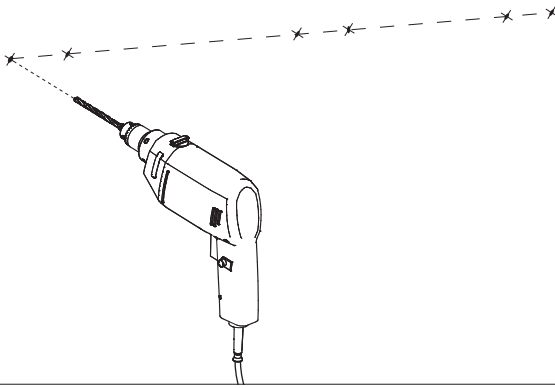

L

4

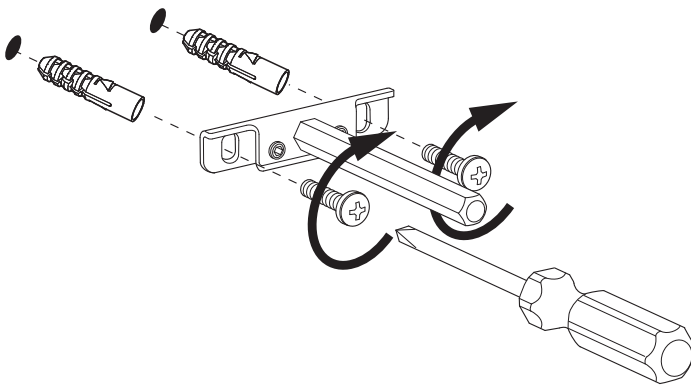

M: 2x

L: 3x

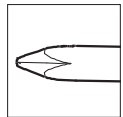

5

M

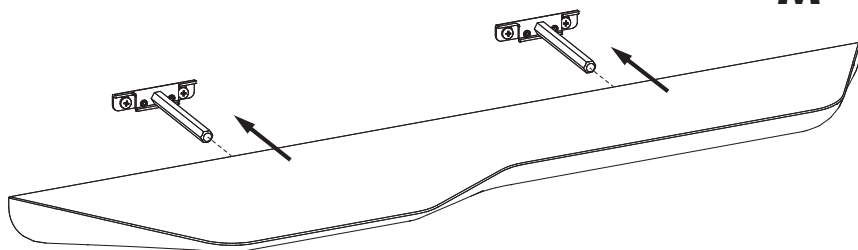

L

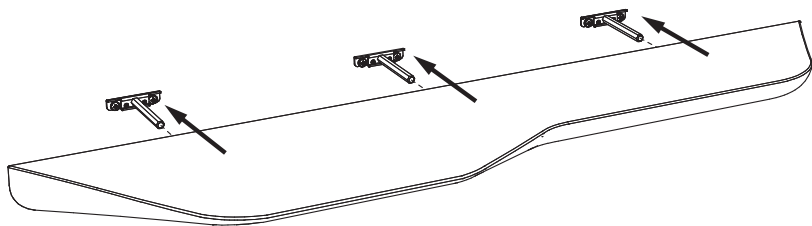

6

6

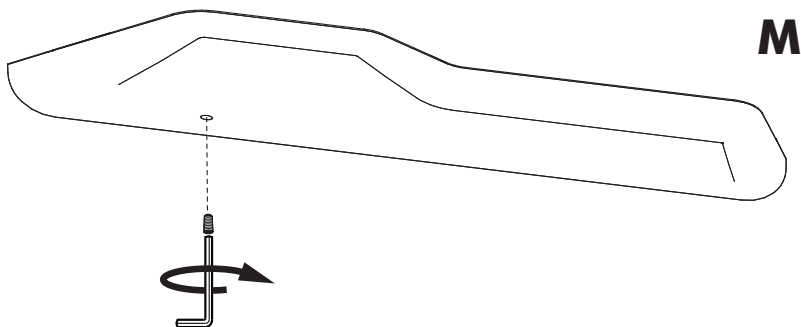

M

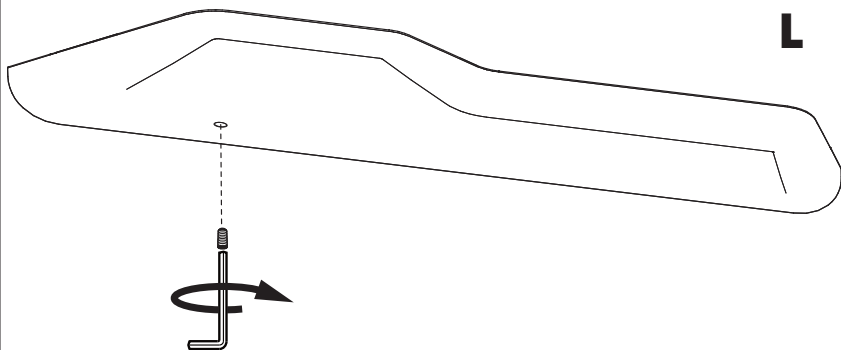

L

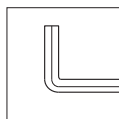

BuzziSpace Group NV
Italiëlei 8, 2000 Antwerp
Belgium

☎ +32 (0)3 846 10 00

✉ info@buzzi.space

🌐 www.buzzi.space

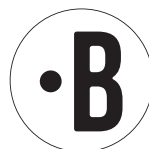

Doc nr.: A-0000001701/01

Last update: 04/12/2023