

ELECTRICAL CONNECTION	
PRIMARY (AC)	L BLACK
	N WHITE
	⊕ GREEN
DIM (OPTIONAL FOR 0-10V SIGNAL)	+ PURPLE or RED
	- GREY or BLUE

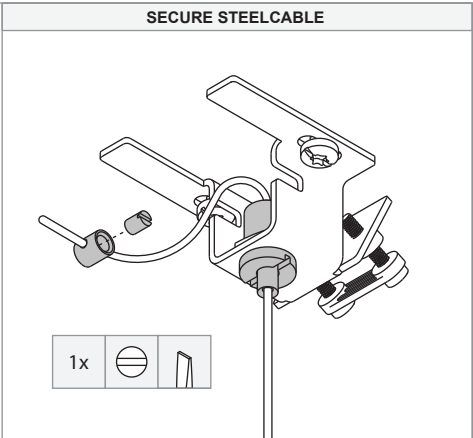

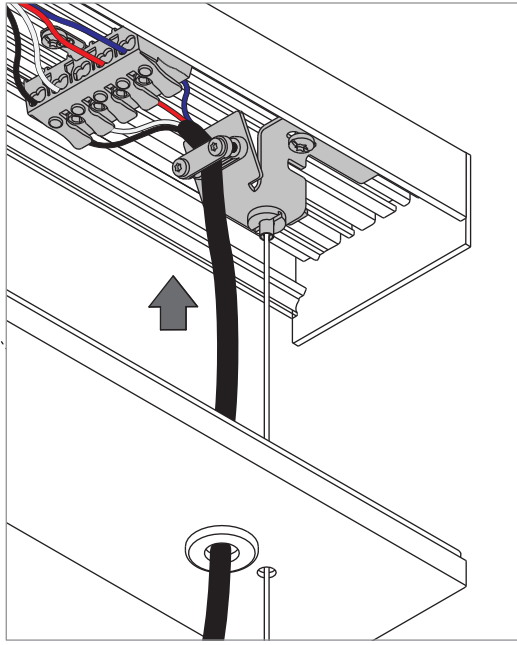
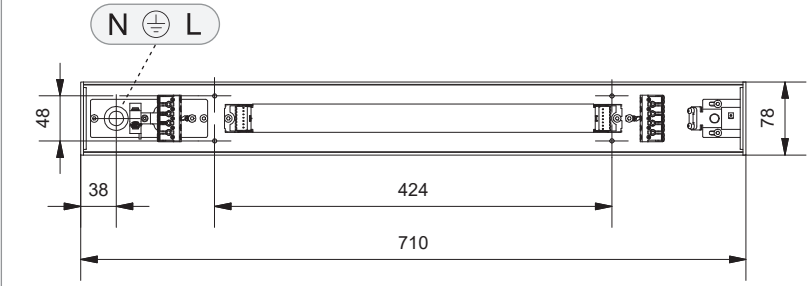
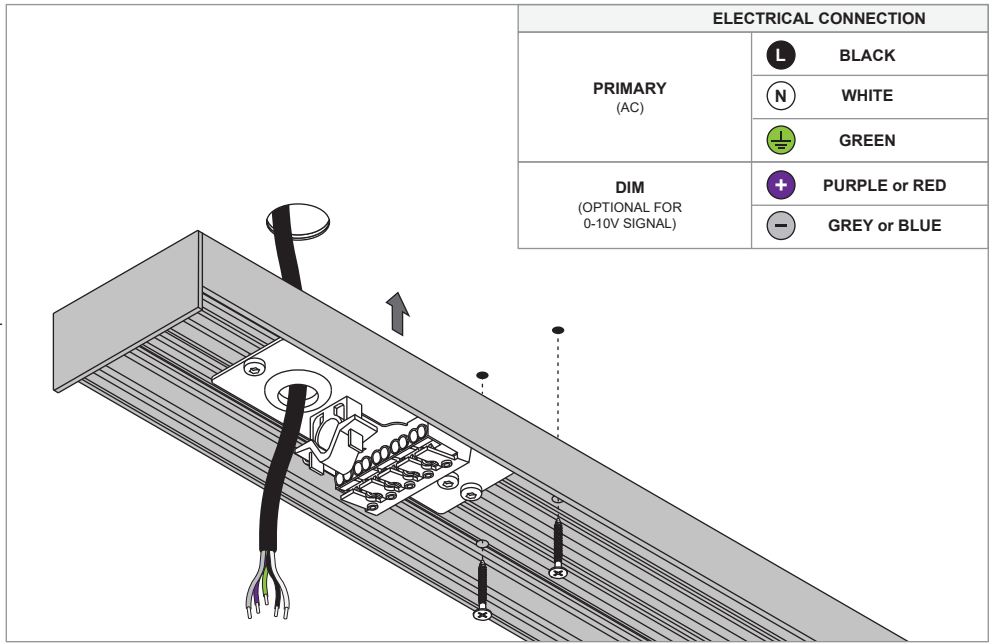

ELECTRICAL CONNECTION	
LED 1	+ BLACK
	- WHITE
LED 2 (OPTIONAL)	+ RED
	- BLUE

BuzziZepp LED US

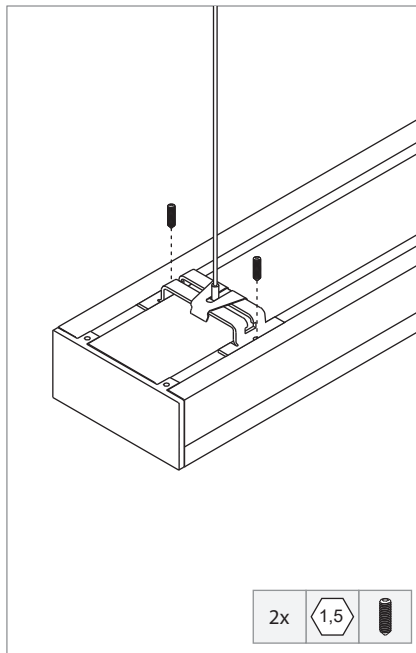
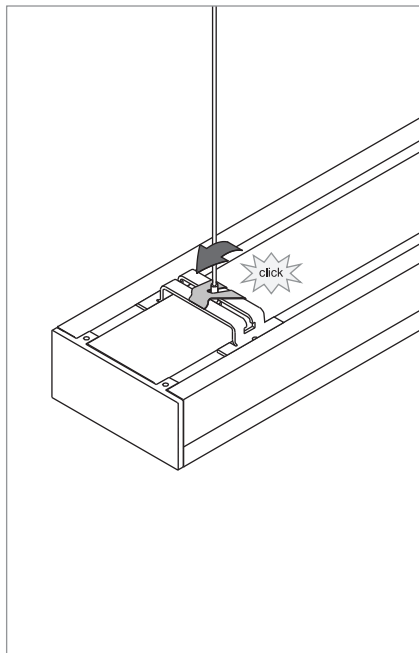
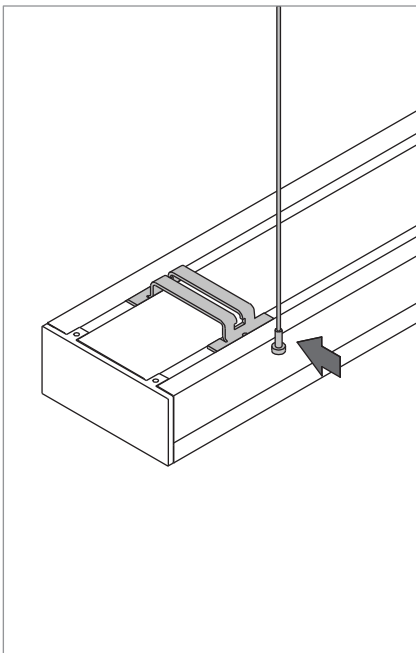
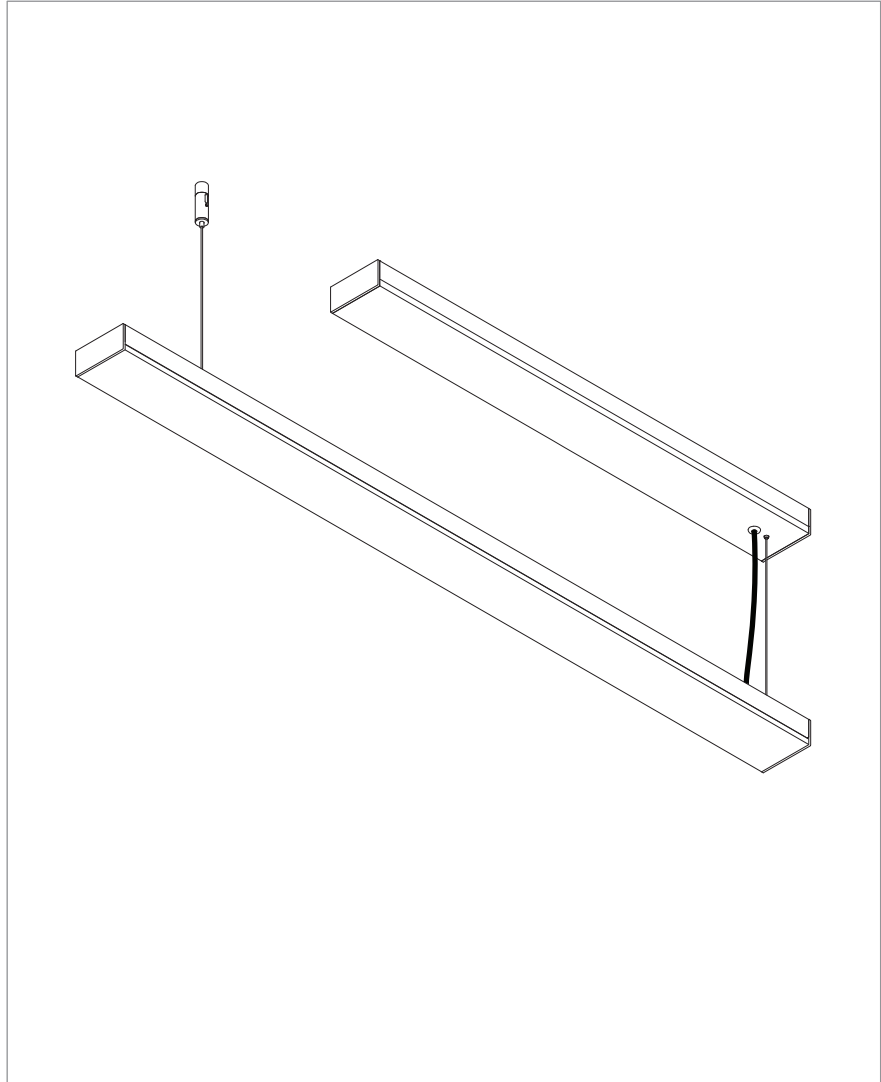
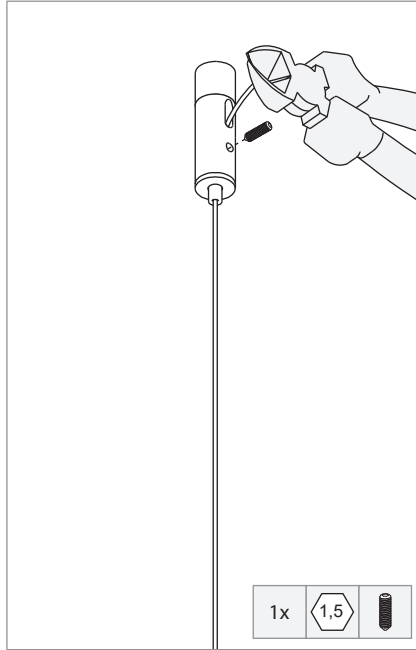
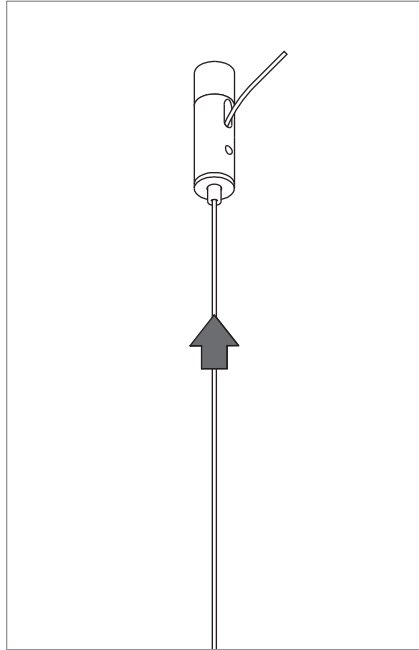
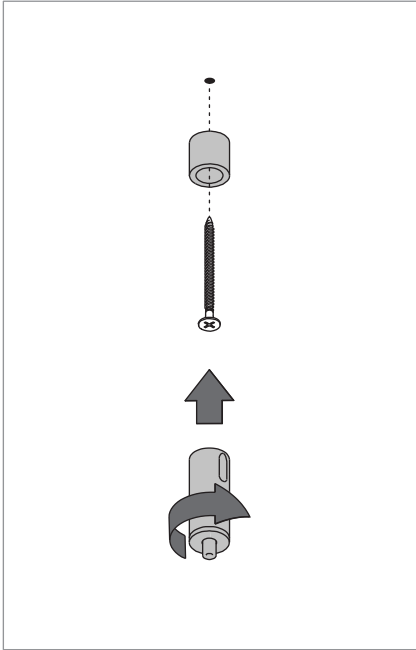
Instruction for LED line



 **LIGHT SOURCE - DO NOT TOUCH LED**
 Touching the LED can result in permanent damage of the light source. The light source and/or driver contained in this luminaire shall only be replaced by the manufacturer or his service agent or a similar qualified person.

 **PREVENTING ELECTROSTATIC DAMAGE**
 A discharge of static electricity may damage sensitive components. Therefore do not touch the LED nor the stripped parts of the wires with bare hands. Always be properly insulated by using ESD gloves.

