

BuzziCee | Cee Half

INSTALLATION MANUAL

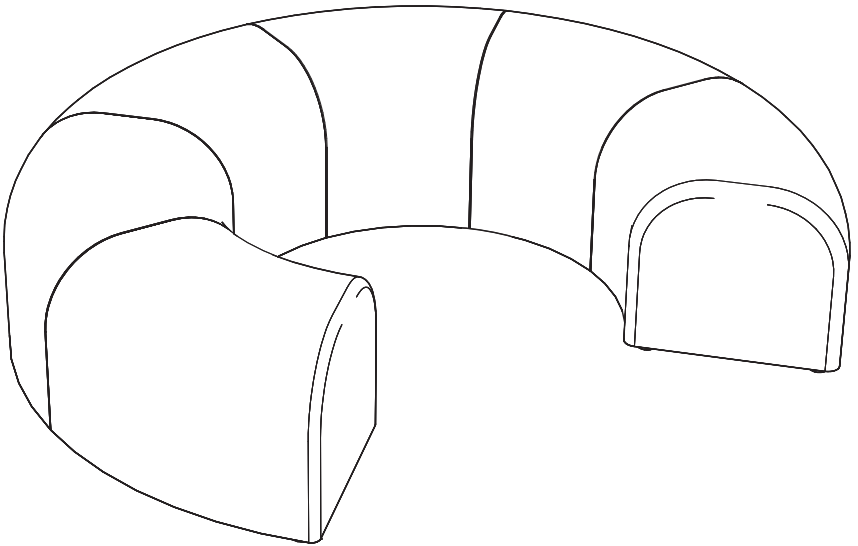

Excluded

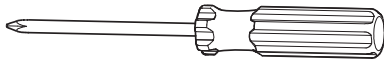

Included BuzziCee

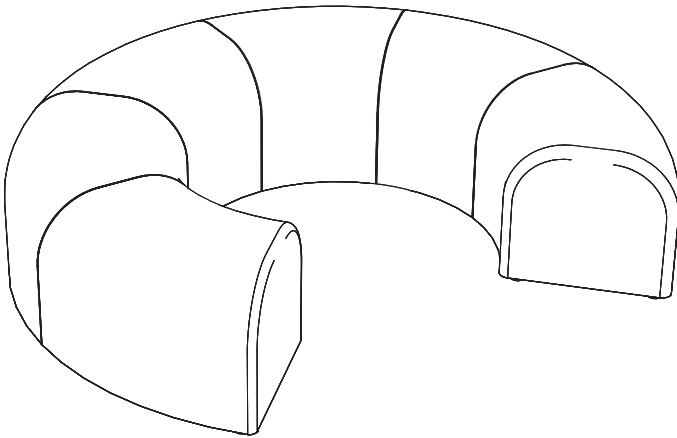

Included BuzziCee Half

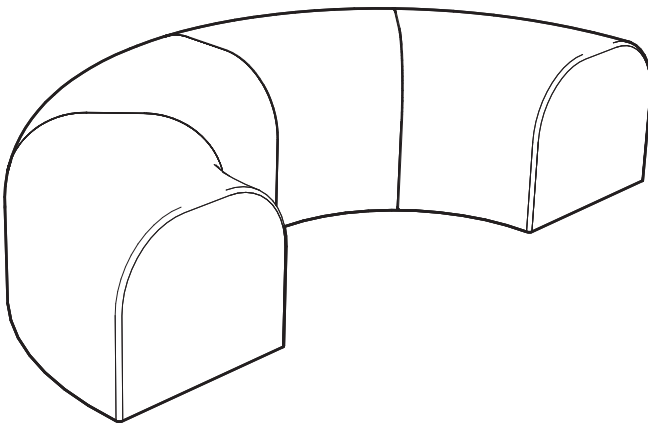

BuzziCee | Cee Half

2 PERS. 

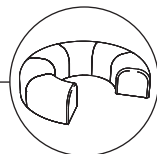

1

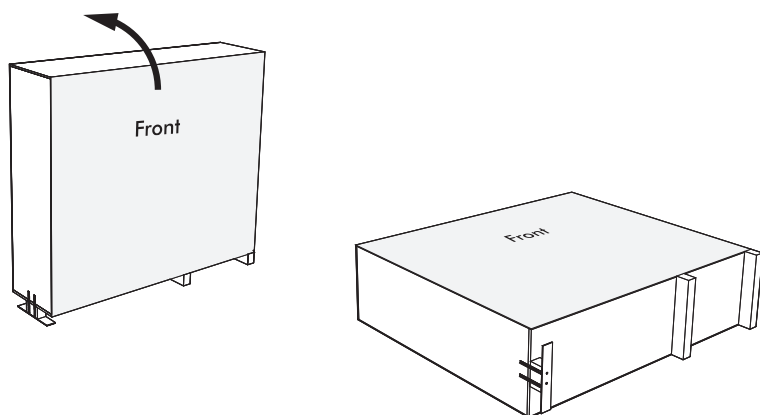

2

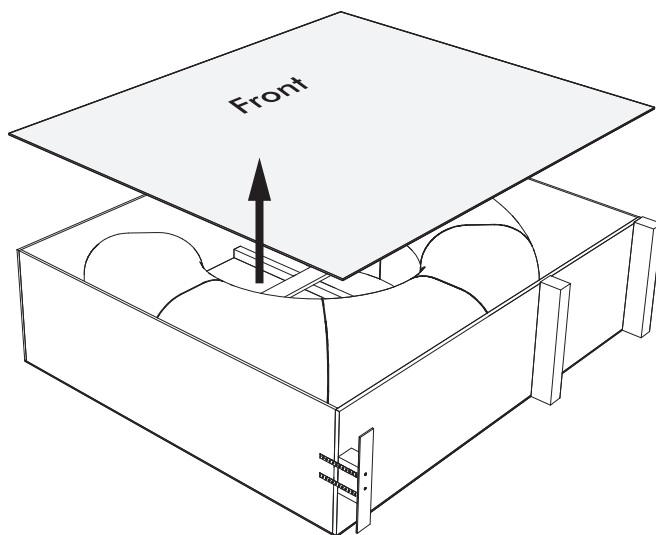

3

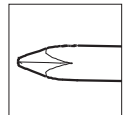
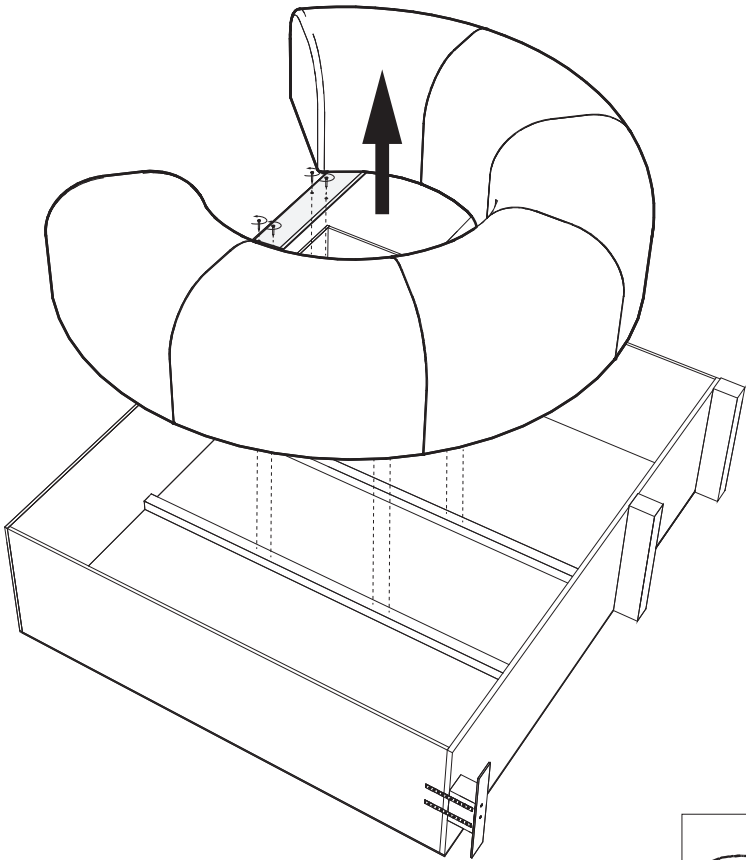
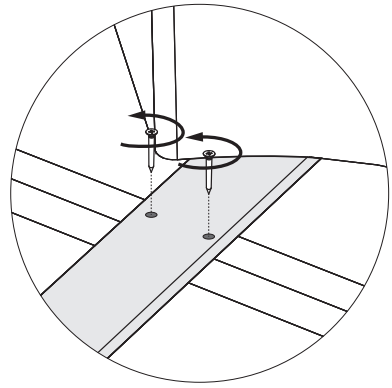

4

4

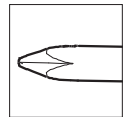
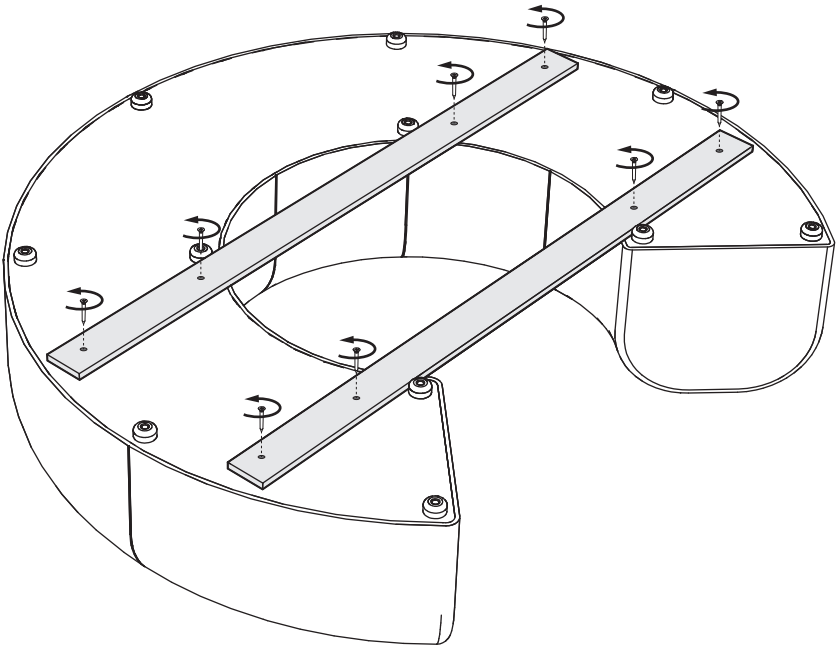
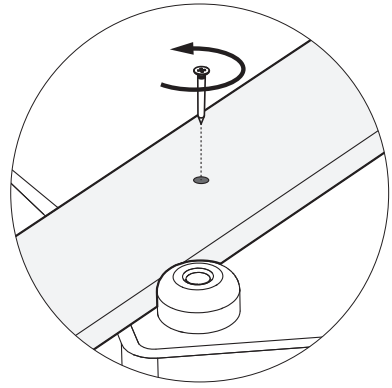

Optional: Connecting multiple BuzziCee Half's

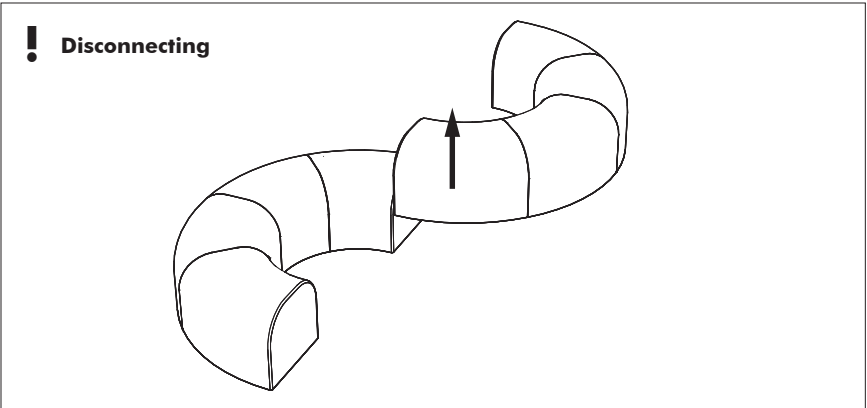
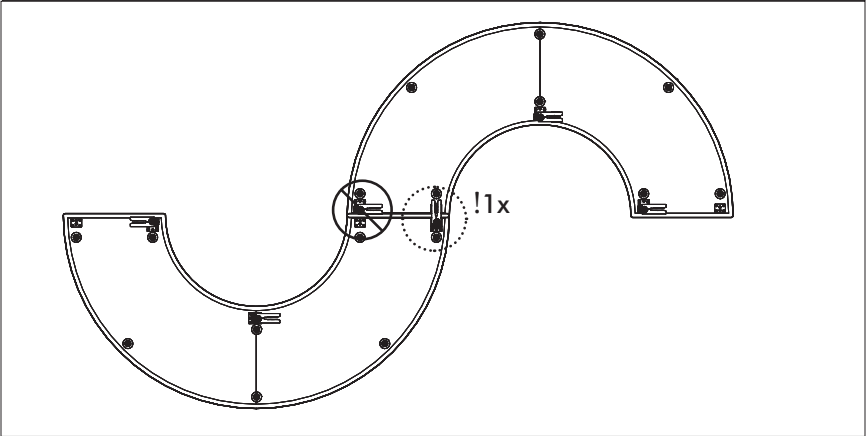
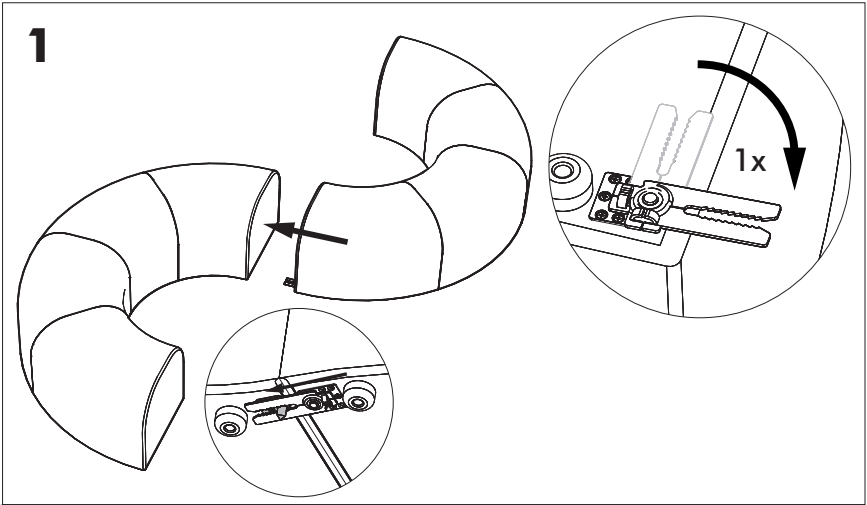

Optional: Connecting two BuzziCee's

1

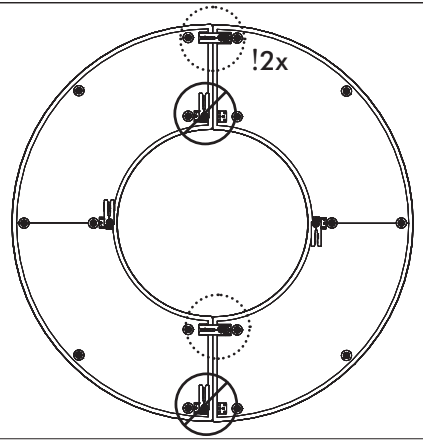
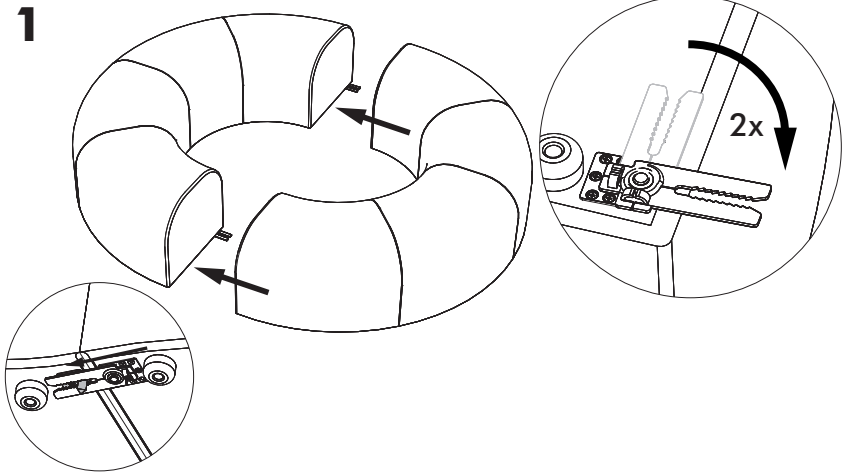

! **Disconnecting**

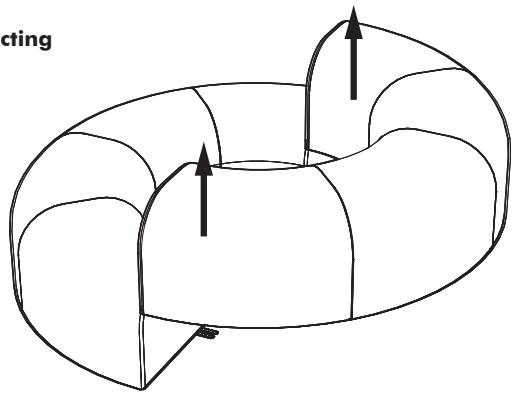

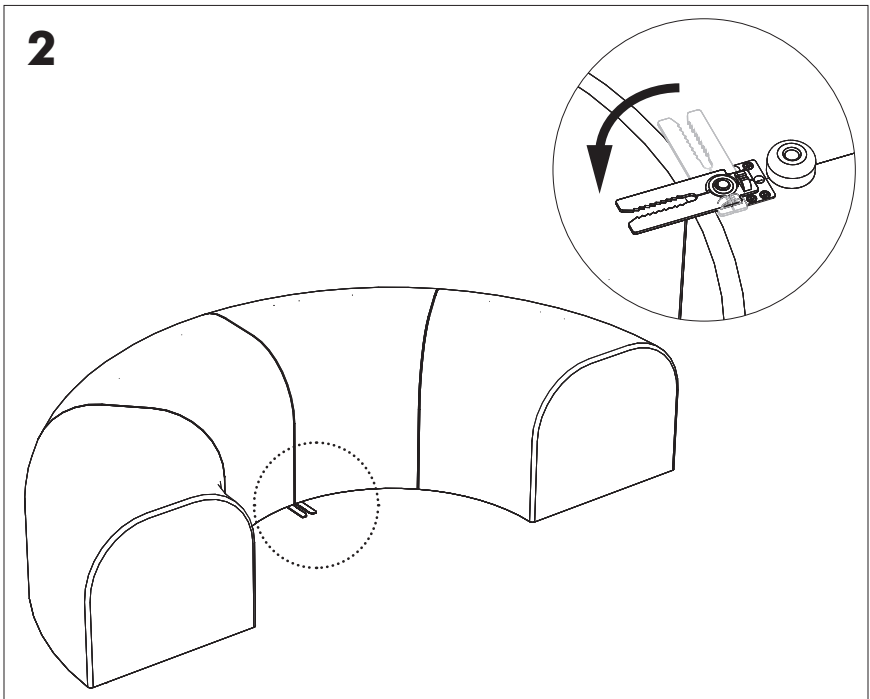
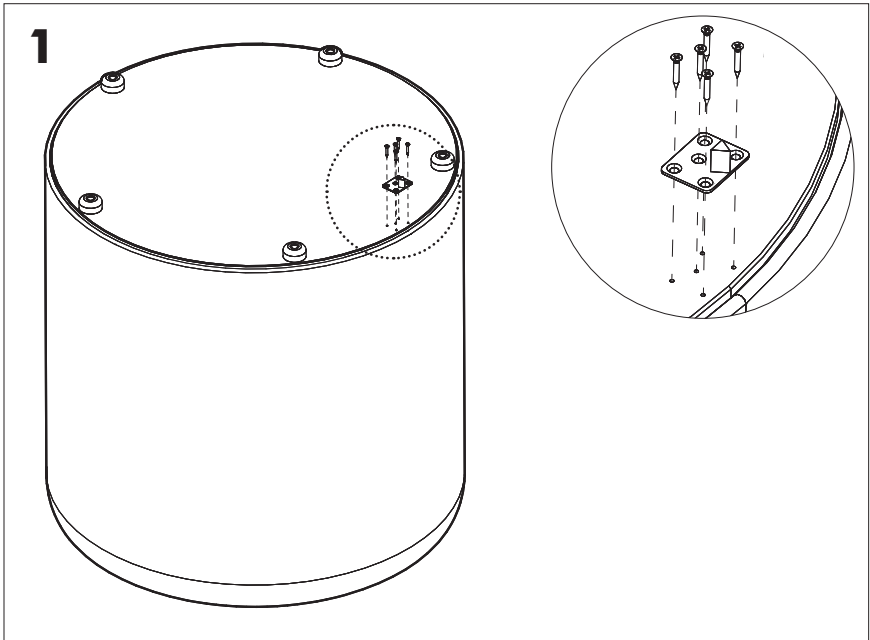

3

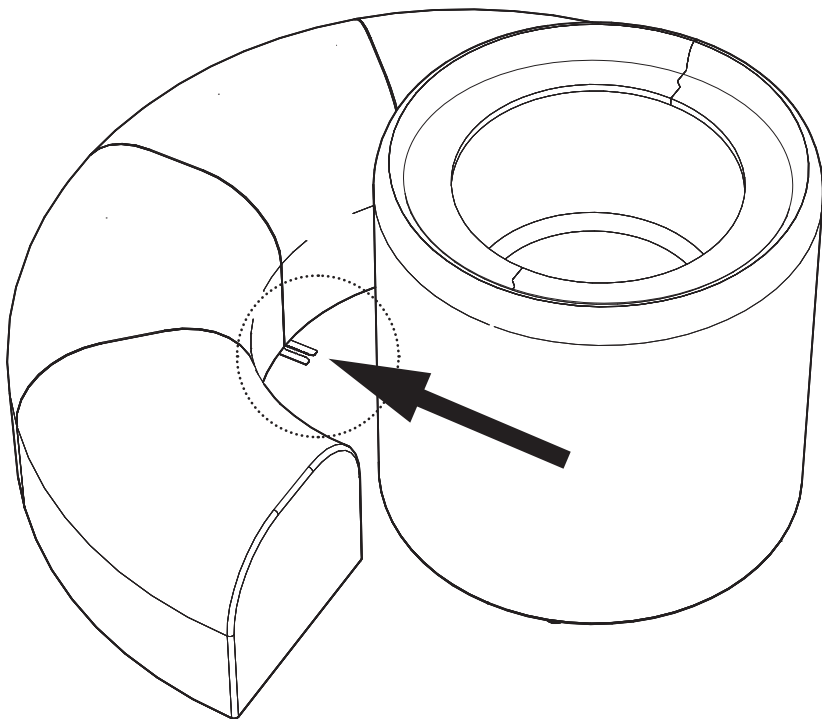
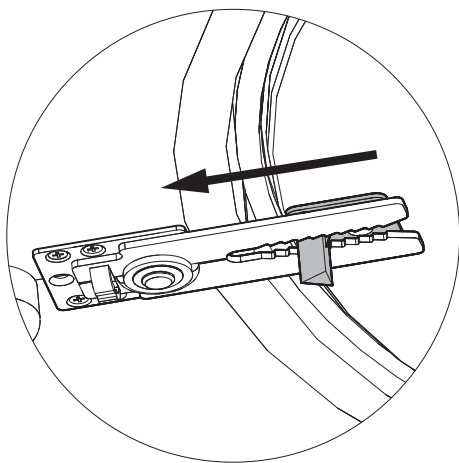

! Disconnecting BuzziPlanter 90 | 90 Half

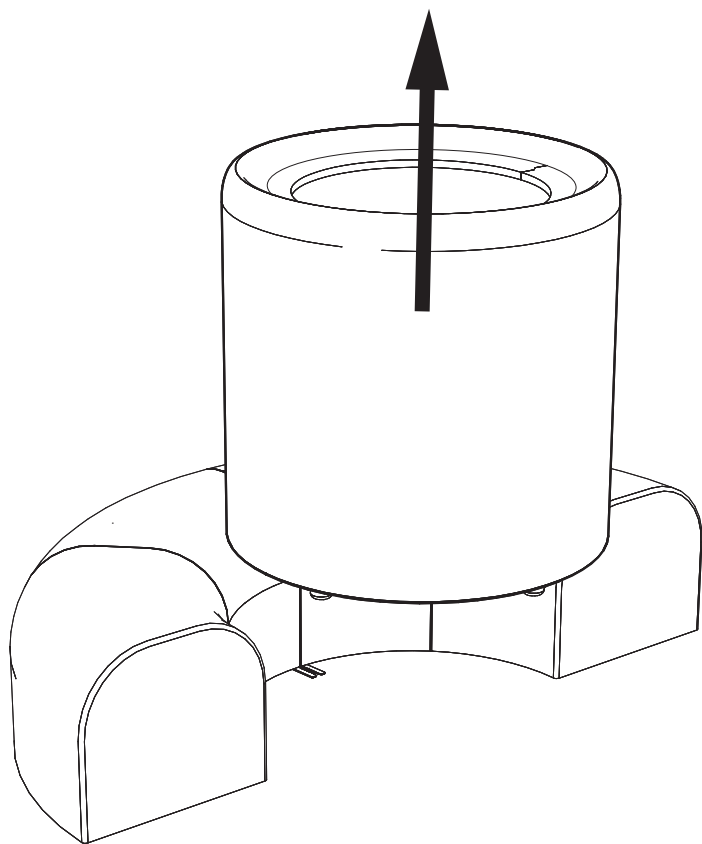

BuzziSpace Group NV
Italiëlei 8, 2000 Antwerp
Belgium

☎ +32 (0)3 846 10 00

✉ info@buzzi.space

🌐 www.buzzi.space



A-0000007361/02
Last update: 16/01/2024