

# BuzziSurf

## Small | Medium | Large

### Retrofit

INSTALLATION MANUAL  
110-120V

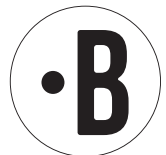
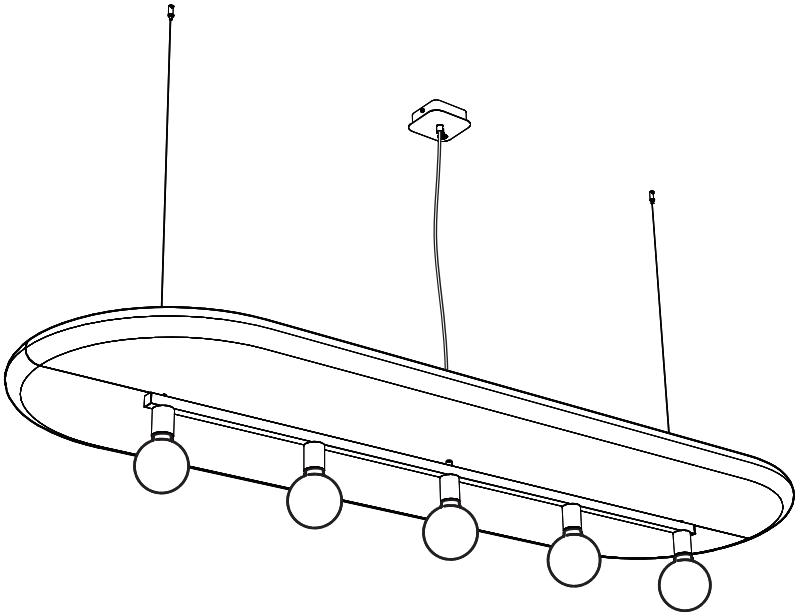

# Technical info

---

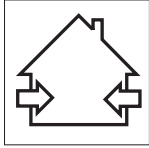

# Excluded

---

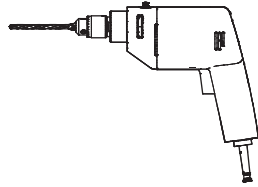
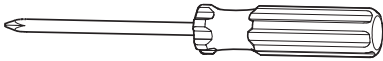
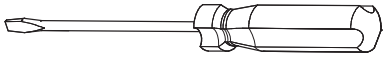

1x

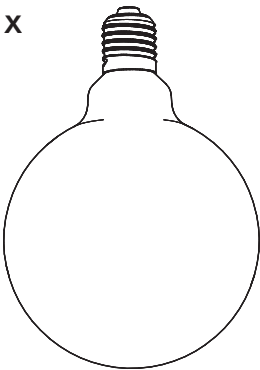

1x

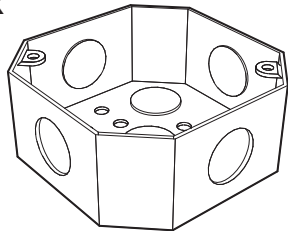

# Included BuzziSurf Small Retrofit

---

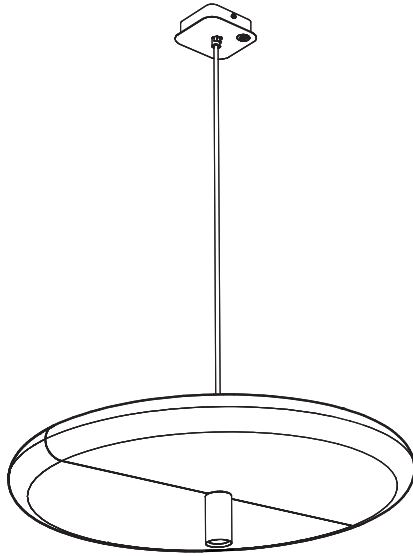

1x



2x



2x



2x

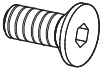

2x



2x



3x



2x



# Included BuzziSurf Medium Retrofit

---

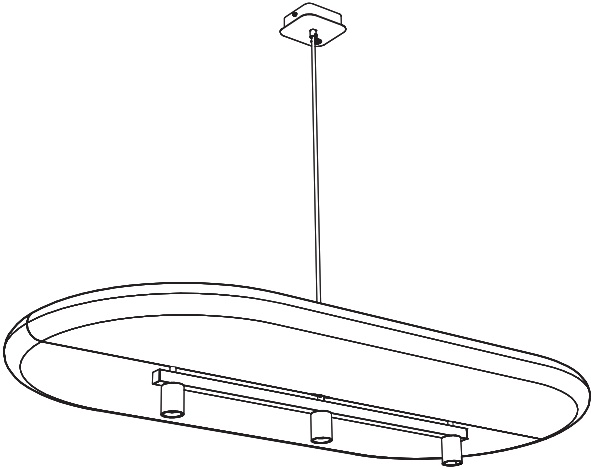

1x



2x



2x



2x



2x



2x

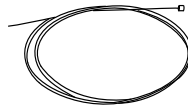

3x

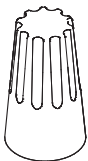

2x



# Included BuzziSurf Large Retrofit

---

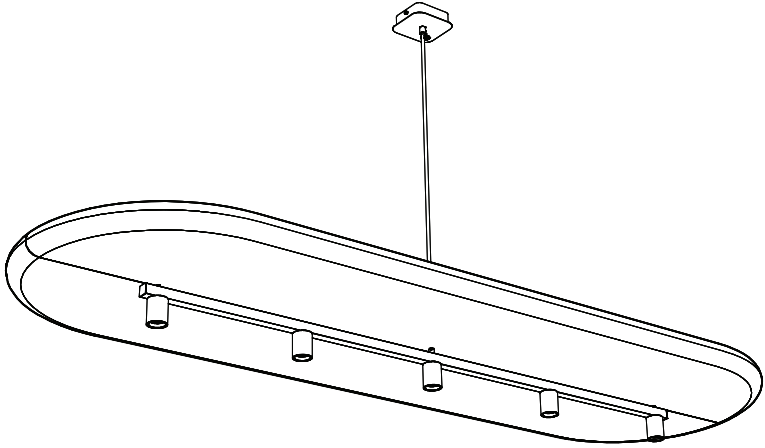

1x



2x



2x



2x

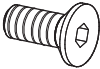

2x



2x



3x

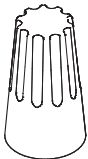

2x



# BuzziSurf Small | Medium | Large Retrofit

1 PERS. 

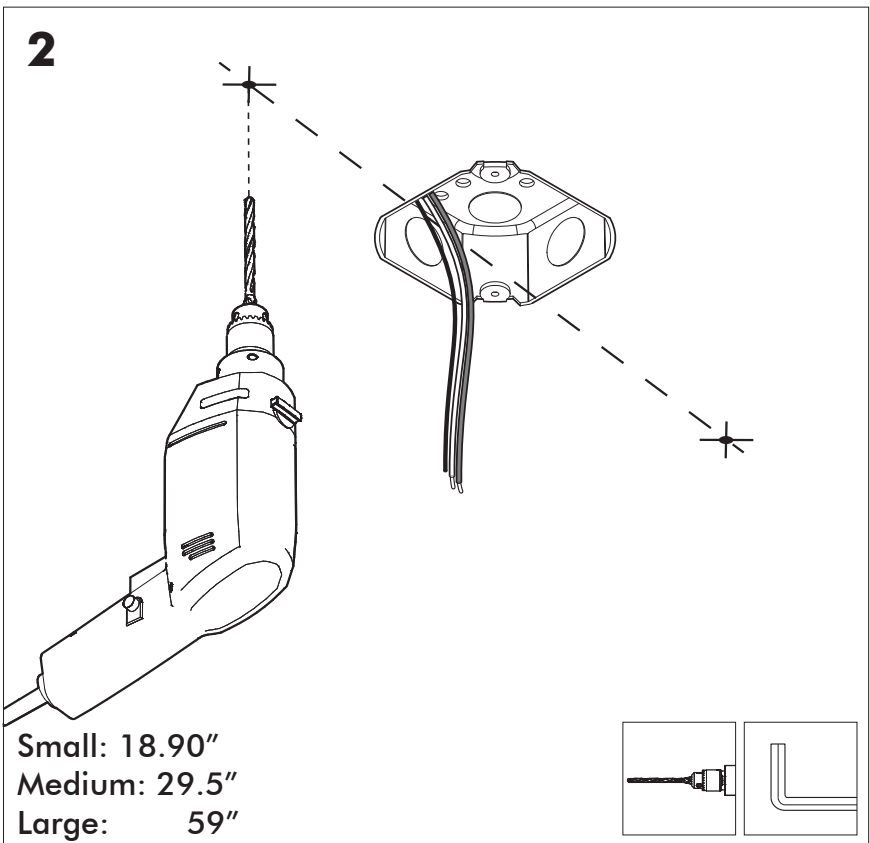
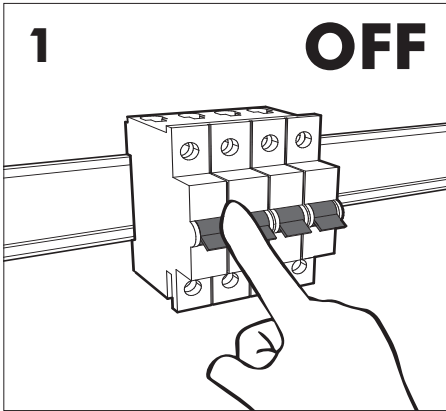

Small: 18.90"  
Medium: 29.5"  
Large: 59"

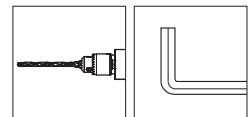

**3**

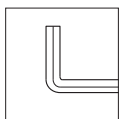
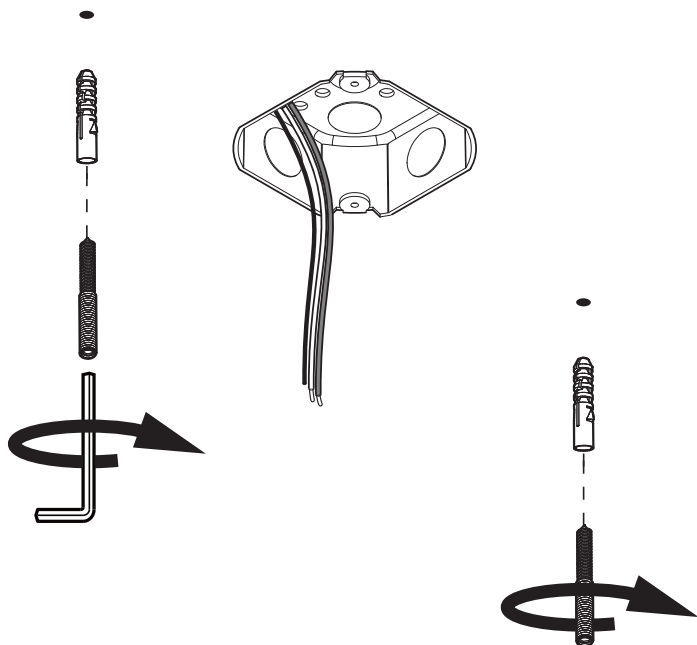

**4**

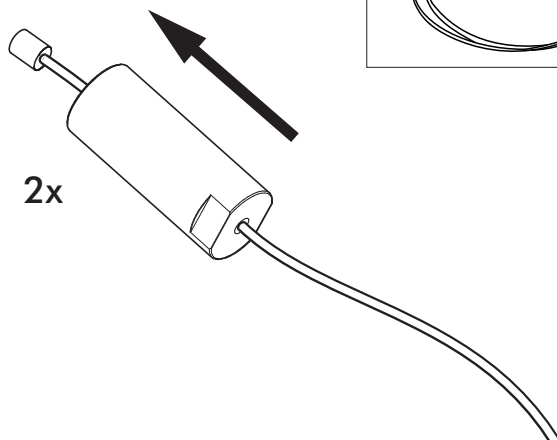

5

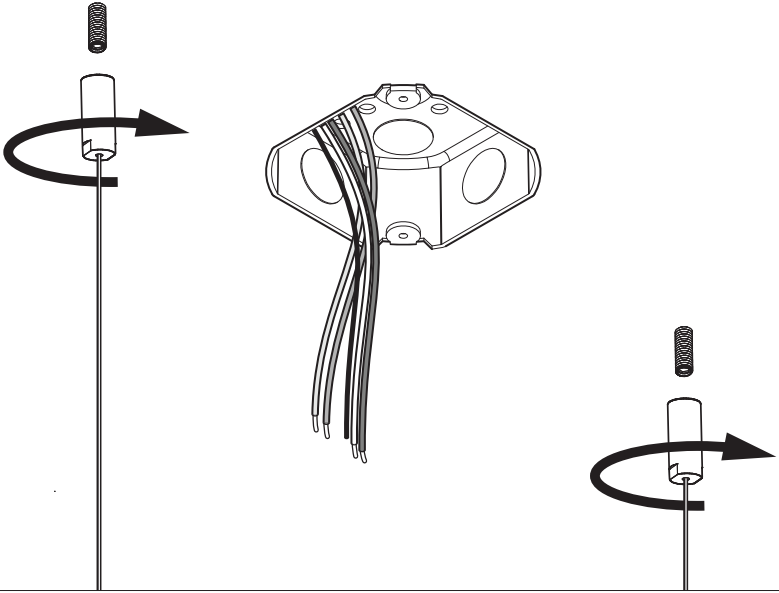

6

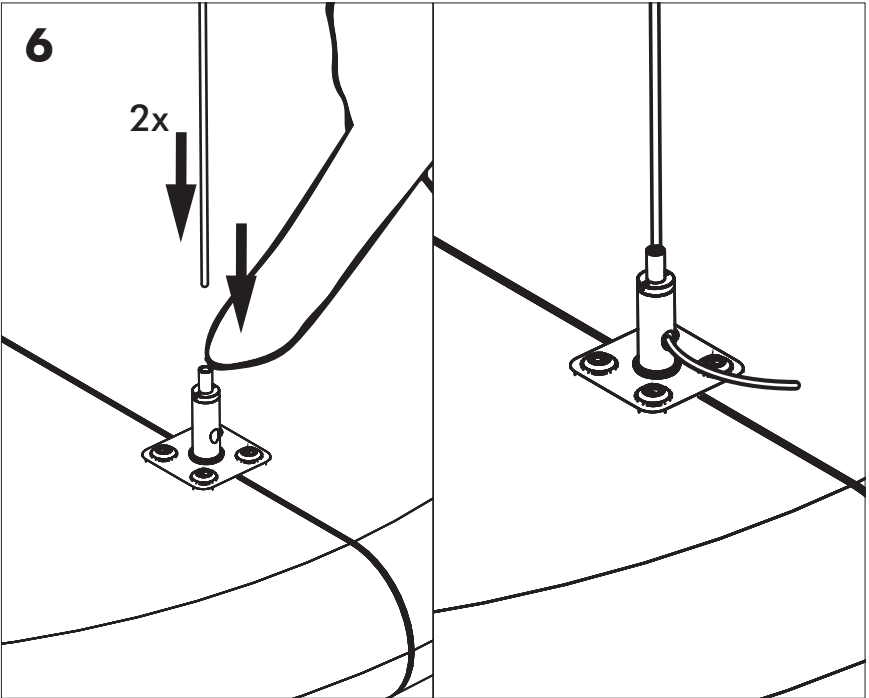



7

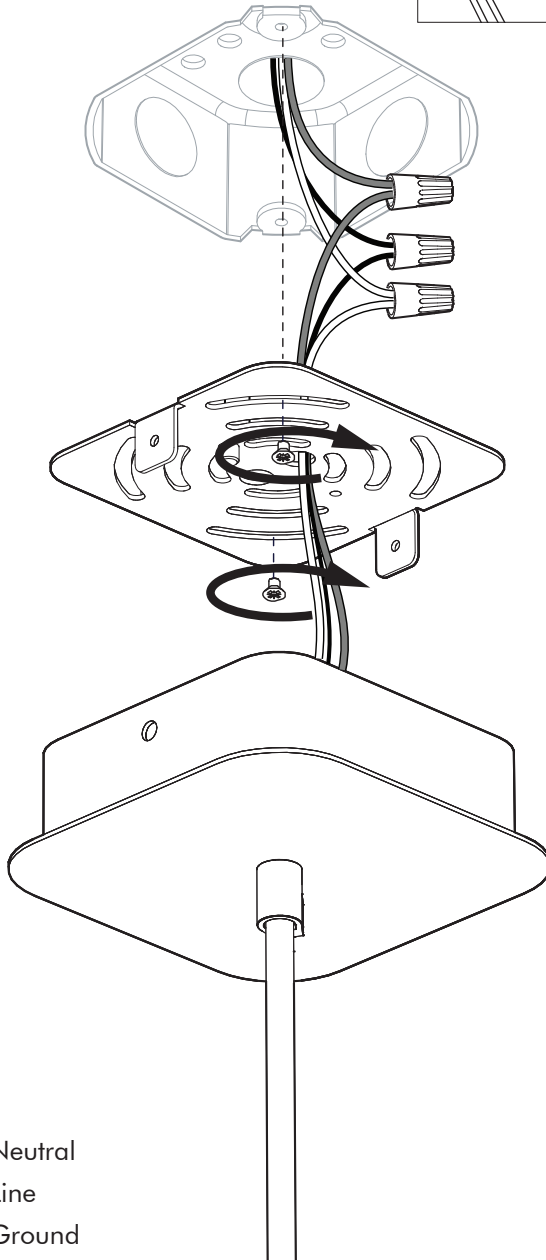
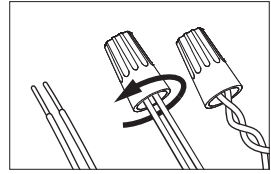

White      Neutral  
Black      Line  
Green      Ground

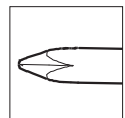

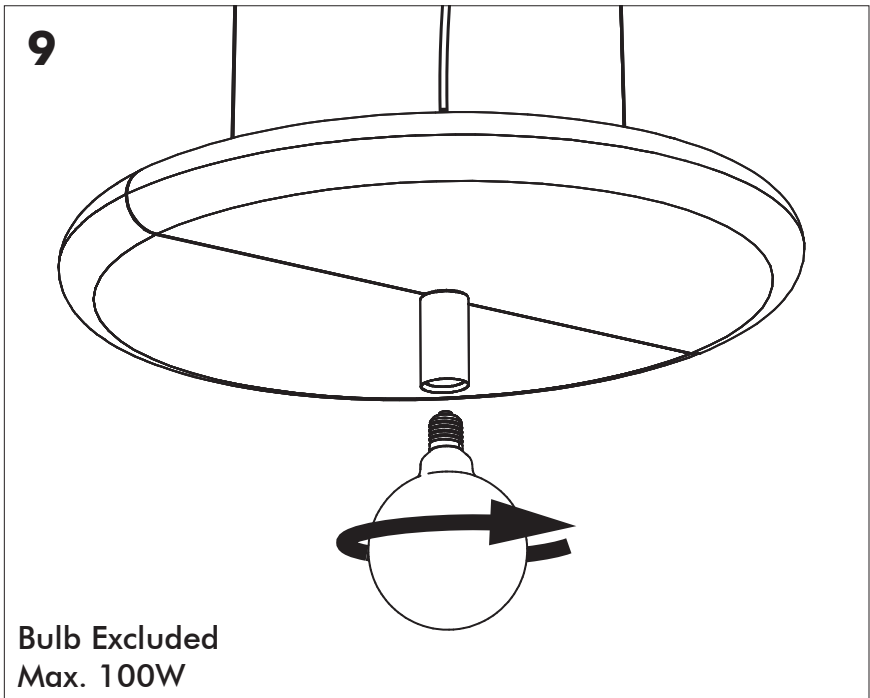
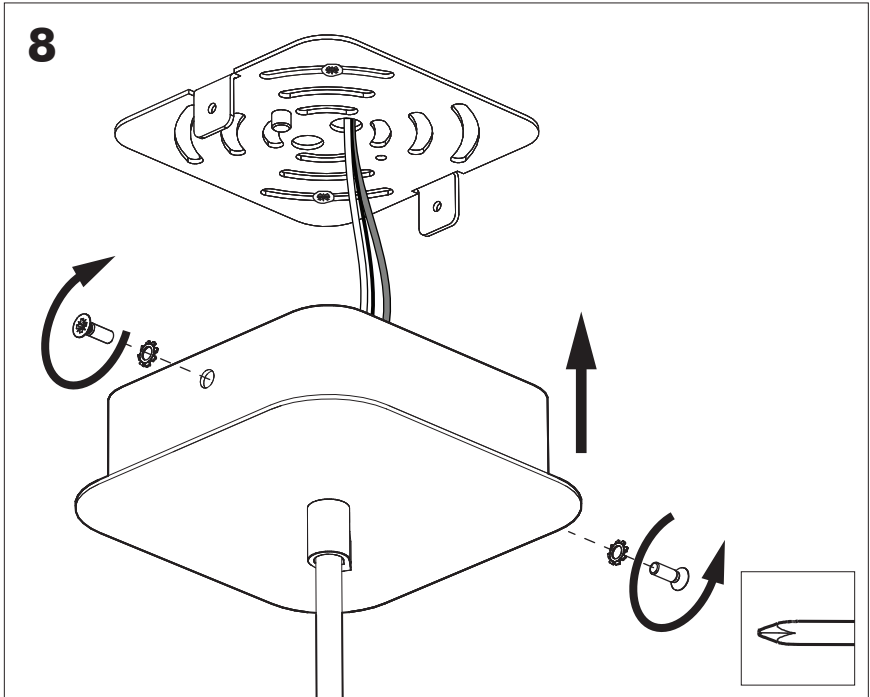

!

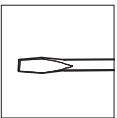
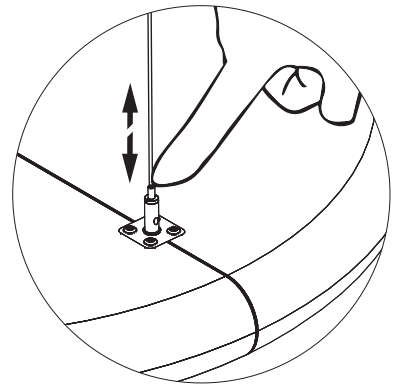
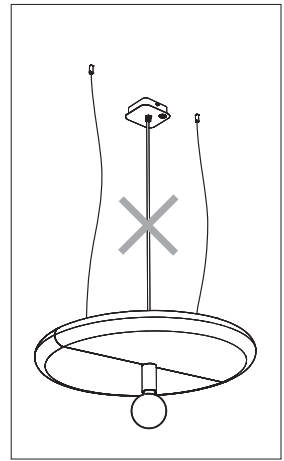
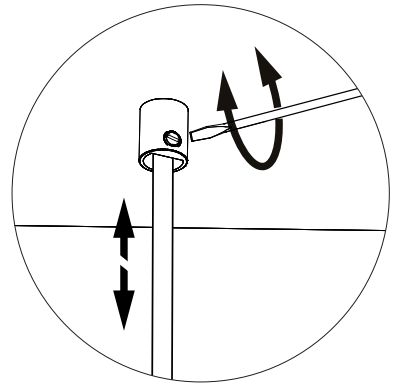
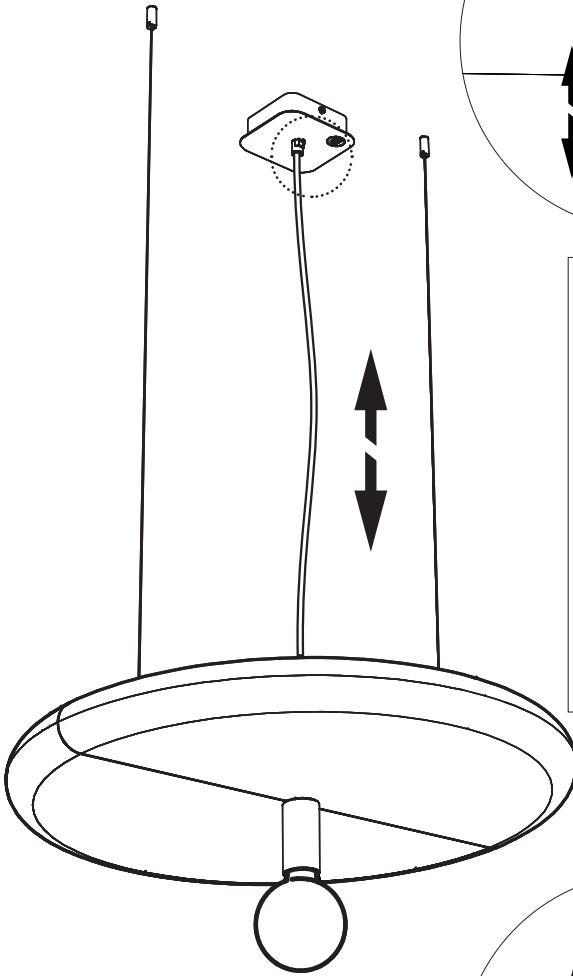

BuzziSpace Group NV  
Italiëlei 8, 2000 Antwerp  
Belgium

☎ +32 (0)3 846 10 00

✉ [info@buzzi.space](mailto:info@buzzi.space)

🌐 [www.buzzi.space](http://www.buzzi.space)



A-0000007942

Last update: 21/02/2024