BuzziCee

Product Specification Sheet

This document contains technical information about the BuzziCee



www.buzzi.space







Centre of attention

Contrary to traditional seating elements, BuzziCee features a symmetrical curved shape that allows colleagues to hold informal meetings or to sit together apart. The unique acoustic seating element is designed to be the ultimate focal point in your workspace and acts as the perfect spot for gatherings whether it be in an open-plan office, reception area, hospitality space, or beyond. BuzziCee's striking design will instantly elevate your open area, all while absorbing excessive noise and creating a sense of togetherness.

Design by BuzziSpace Studio

General

-  BuzziCee | BuzziCee Half
-  Upholstered acoustic foam seating element
Fabrics: Fabric, Trevira CS, Velvet, Remix 3, Clara 2, Hero 2, Tonus 4, Arda or Memory 2
-  Dry Use
-  Assembled

Acoustics



Absorption



Diffusion



Low Tone



Mid Tone



High Tone



Content

Configurations	3
Components	4
Fabrics	6
Dimensions	8
Acoustics	9

Configuration

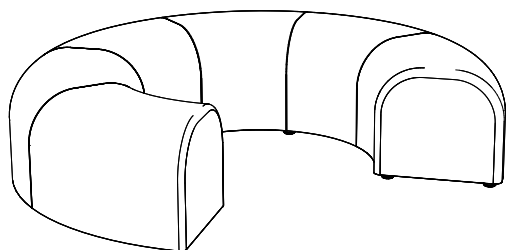

BuzziCee

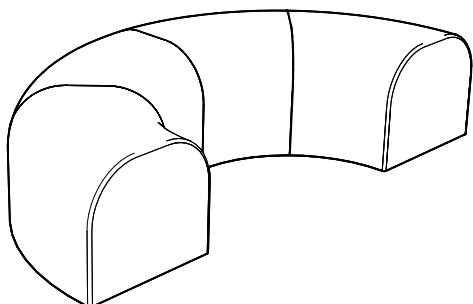

-  Upholstered acoustic foam seating element
Fabrics: Fabric, Trevira CS, Velvet, Remix 3, Clara 2, Hero 2, Tonus 4, Arda or Memory 2
-  Outer: Ø 193 cm | 75.98"
Inner: Ø 93 cm | 36.61"
Height: 46 cm | 18.11"
-  47 kg | 130.62 lbs

BuzziCee Half



-  Upholstered acoustic foam seating element
Fabrics: Fabric, Trevira CS, Velvet, Remix 3, Clara 2, Hero 2, Tonus 4, Arda or Memory 2
-  Width: 193 cm | 75.98"
Depth: 96,5 cm | 37.99"
Height: 46 cm | 18.11"
-  30,5 kg | 67.24 lbs

Components

Plastic Feet



Bottom: Black fabric with plastic Feet

Crocodile System



With the crocodile system located at the bottom, you can easily link various Cee and Cee Half elements together.

It also allows you to link a Cee or Cee Half with Planter 90 and Planter 90 Half.

Inspiration Models

1x BuzziPlanter 90 Half
1x BuzziCee Half



1x BuzziPlanter 90
2x BuzziCee Half



1x BuzziPlanter 90
1x BuzziCee
2x BuzziCee Half



Fabrics

Fabric (45 colors)

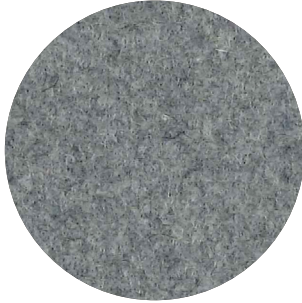

Category A

Composition 70% Recycled Wool, 25% Recycled Polyacryl,
5% Recycled Other Fabrics

Weight 405 g/m² | 11.94 oz/yd²

Abrasion resistance 40.000 Martindale, 50,000 Wyzenbeek

Flammability EU: EN 1021.1/2006 | BS EN 1021.1/2006 (cigarette).
EN 1021.2/2006 | BS EN 1021.2/2006 (match)
USA: CAL TB 117 | ASTM E84 CLASS A

Fastness to light EU: 4 | USA 4

Fastness to rubbing EU: Wet 3-4 | Dry 4-5

Fastness to crocking USA: Wet 5 | Dry 5



Trevira CS (47 colors)

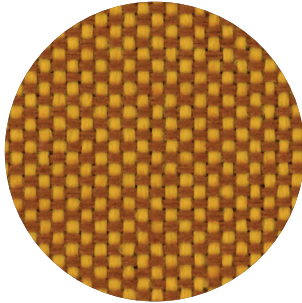

Category A

Weight 420 g/m² | 12.39 oz/yd²

Composition 100% Polyester, Trevira CS

Abrasion resistance 100.000 Martindale, 90,000 Wyzenbeek

Flammability BS 5852 part II: CRIB 5 | BS 7176 Medium Hazard
USA: CAL TB 117 | M1 | B1 | EN 1021/1-2 | C1 |
IMO Res. A652 (16)

Fastness to light EU: 6 | USA 5

Fastness to rubbing EU: Wet 4-5 | Dry 4-5

Fastness to crocking USA: Wet 5 | Dry 5



Velvet (12 colors)

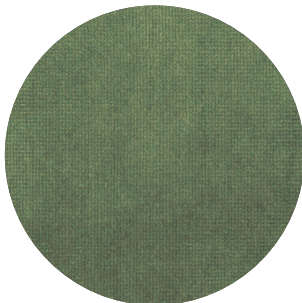

Category B

Composition 100% PES

Weight 375 g/m² | 11.06 oz/yd²

Abrasion resistance > 100.000 Martindale

Fastness to light EU: 4-5

Fastness to rubbing EU: Wet 4 | Dry 4-5

Pilling EU: 4-5

Clara 2 (24 colors)

kvadrat

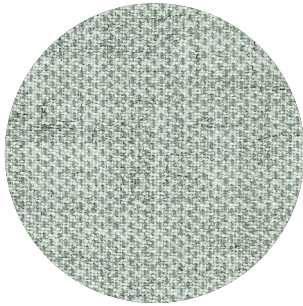

Category B

Composition 92% new wool, 8% nylon

Weight 400 g/lin.m

Abrasion resistance 80.000 Martindale rubs, EN ISO 12947

Flammability EN 1021-1/2 | BS 5852, ignition source 2-3 | DIN 4102 B2
NF D 60 013 | UNI 9175 11M | US Cal. Tech. Bull. 117, Sec. E
NFPA 260 | IMO A.652(16)

Fastness to light Note 5-7, ISO 105-B02

Fastness to rubbing (ISO) dry 4-5, wet 4

Pilling Note 4, EN ISO 12945



Remix 3 (73 colors)

kvadrat



Category B

Composition 90% new wool, 10% nylon

Weight 415 g/lin.m

Abrasion resistance 100.000 Martindale rubs, EN ISO 12947

Flammability EN 1021-1/2 | BS 5852 part 1
Önorm B1/Q1 | NF D 60 013 | UNI 9175, 11M
AS/NZS 1530.3 | Cal. Tech. Bull. 117-2013
NFPA 260 | IMO FTP Code 2010:Part 8

Fastness to light Note 5-7, ISO 105-B02

Fastness to rubbing (ISO) dry 4-5, wet 4

Pilling Note 4, EN ISO 12945



Hero 2 (33 colors)

kvadrat

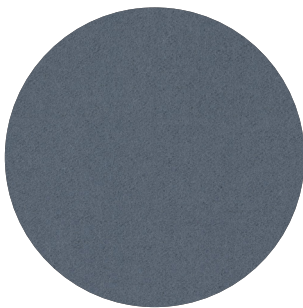

Category C

Composition 97% new wool, 3% nylon

Weight 580 g/lin.m

Abrasion resistance 45.000 Martindale rubs, EN ISO 12947

Flammability EN 1021-1/2 | DIN 4102 B2 | NF D 60 013
UNI 9175 11M | US Cal. Bull. 117-2013 | NFPA 260
IMO A.652 (16)

Fastness to light Note 5-6, ISO 105-B02

Fastness to rubbing (ISO) dry 4-5, wet 4-5

Pilling Note 3-4, EN ISO 12945



Tonus 4 (47 colors)

kvadrat

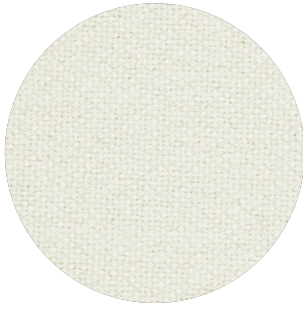

Category D

Composition 90% new wool, 10% Helanca

Weight 665 g/lin.m

Abrasion resistance 100.000 Martindale rubs, EN ISO 12947

Flammability EN 1021-1/2 | BS 5852 part 1 | DIN 4102 B2

Önorm B1/Q1 | NF D 60 013 | UNI 9175 11M

US Cal. Bull. 117-2013 | NFPA 260 | IMO A.652 (16)

Fastness to light Note 5-7, ISO 105-B02

Fastness to rubbing (ISO) dry 3-5, wet 3-5

Pilling Note 3, EN ISO 12945



Arda (12 colors)

kvadrat

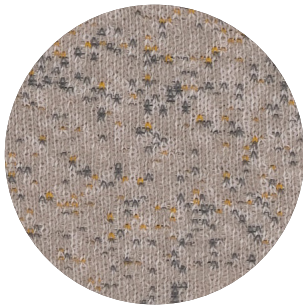

Category E

Composition 70% new wool 21% polyester 9% nylon

Weight 800 g/lin. m | 25.8 oz/ly

Abrasion resistance

Approx. 50.000 Martindale rubs, EN ISO 12947

Flammability ASTM E84 Class A Unadhered | AS/NZS 3837 class 2 | BS 5852 part 1

BS 5852 crib 5 | DIN 4102 B2 | EN 1021-1/2 | IMO FTP Code 2010 Part 8

UNI 9175 11M | US Cal. Bull. 117-2013

Fastness to light Note 5-8, ISO 105-B02

Fastness to rubbing Dry note 3-5 ISO 105-X12

Wet note 3-5 ISO 105-X12

Pilling Note 4, EN ISO 12945



Memory 2 (20 colors)

kvadrat

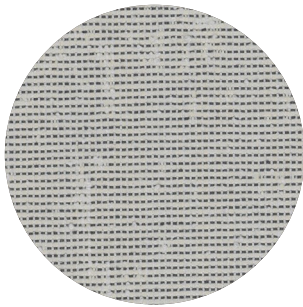

Category E

Composition 100% Trevira CS

Weight 700 g/lin.m

Abrasion resistance

35.000 rubs acc. to the Martindale method, EN ISO 12947

Flammability EN 1021-1/2 | DIN 4102 B1 | Önorm B1/Q1

NF D 60 013 | NF P 92 507 M1 | UNI 9175 11M

UNI 9177 classe 1 | US Cal. Tech. Bull. 117

IMO A.652 (16)

Fastness to light Note 5-8, ISO 105-B02

Fastness to rubbing (ISO) dry 4-5, wet 4-5

Pilling Note 4, EN ISO 12945



Dimensions

BuzziCee

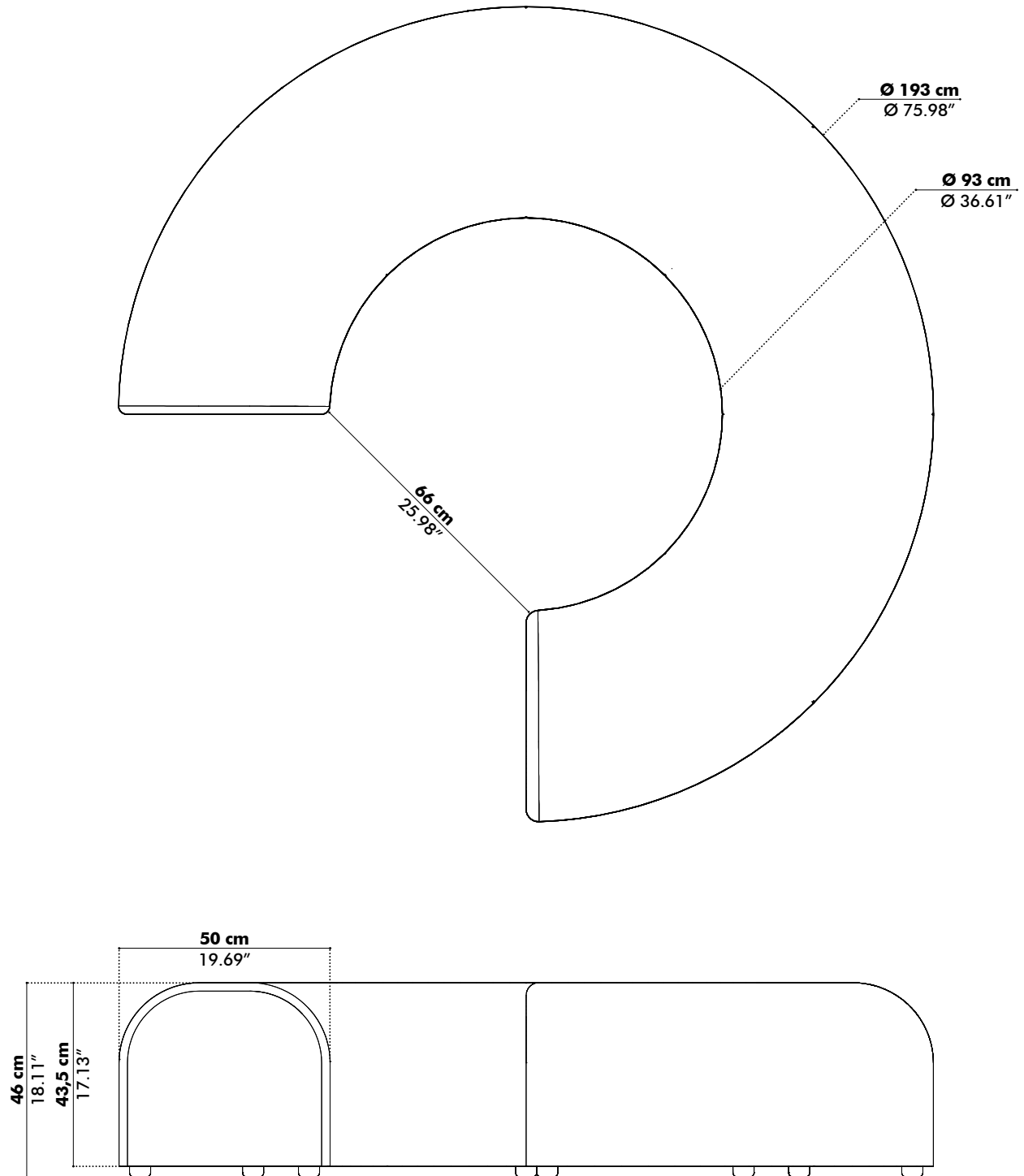

BuzziCee Half

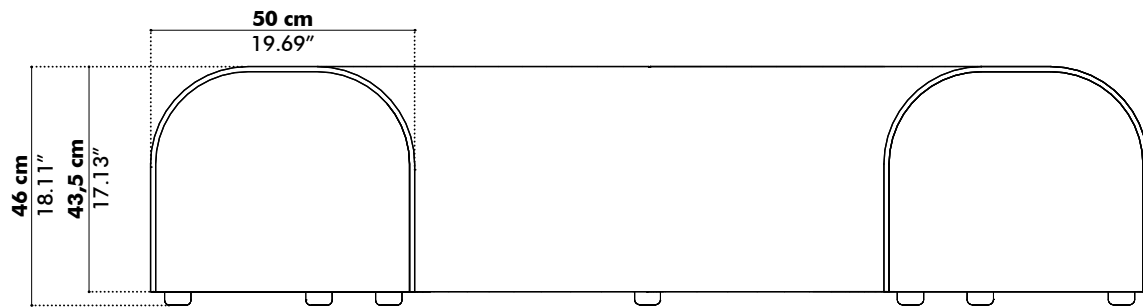
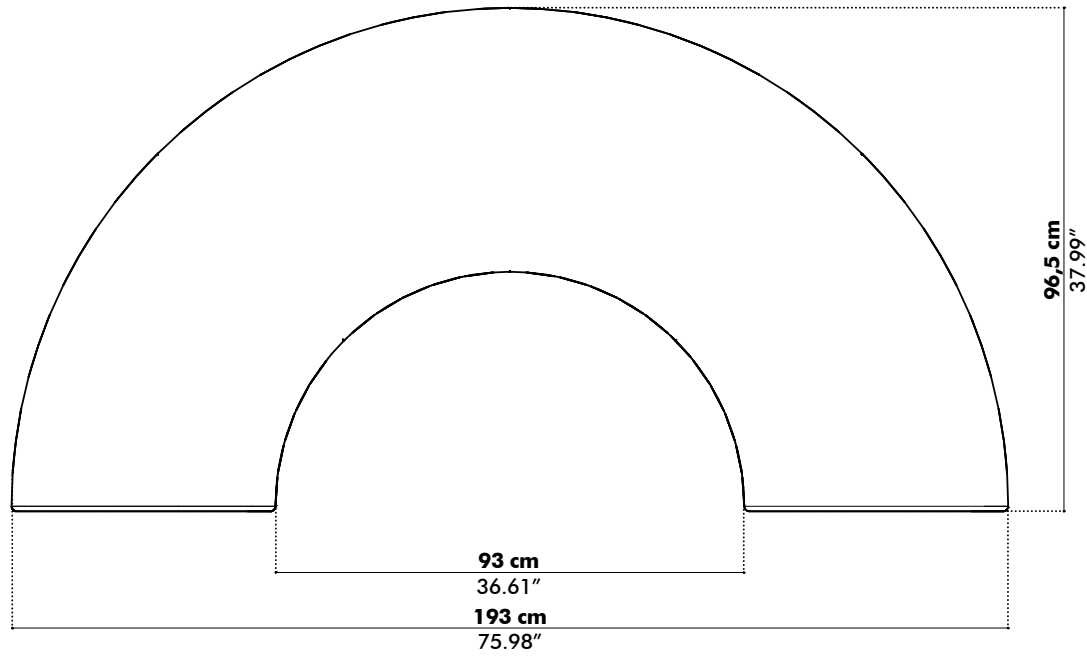

Acoustics

BuzziCee

Equivalent sound absorption area in m² per object

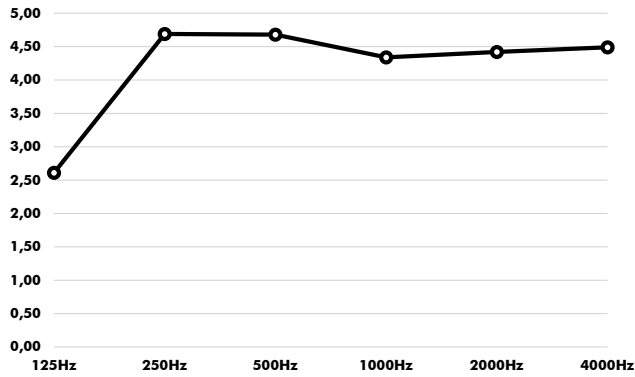

Hz	Aeq/m ²
125	2.61
250	4.69
500	4.68
1000	4.34
2000	4.42
4000	4.49