



Product Specification Sheet

BuzziTent Light EU

— By Alain Gilles

Circular by Nature. Lighting by Design.

Designed by Alain Gilles, BuzziTent Light is a high-performance suspended acoustic lighting solution that combines mid-to-high frequency sound absorption with integrated architectural illumination. Crafted from 60% recycled PET felt and designed to be fully disassemblable and 100% recyclable, BuzziTent Light delivers acoustic comfort, lighting performance, and circular design in one integrated ceiling solution.



The Family

Model

BuzziTent Light

Lighting Unit
LED Line Glow 140

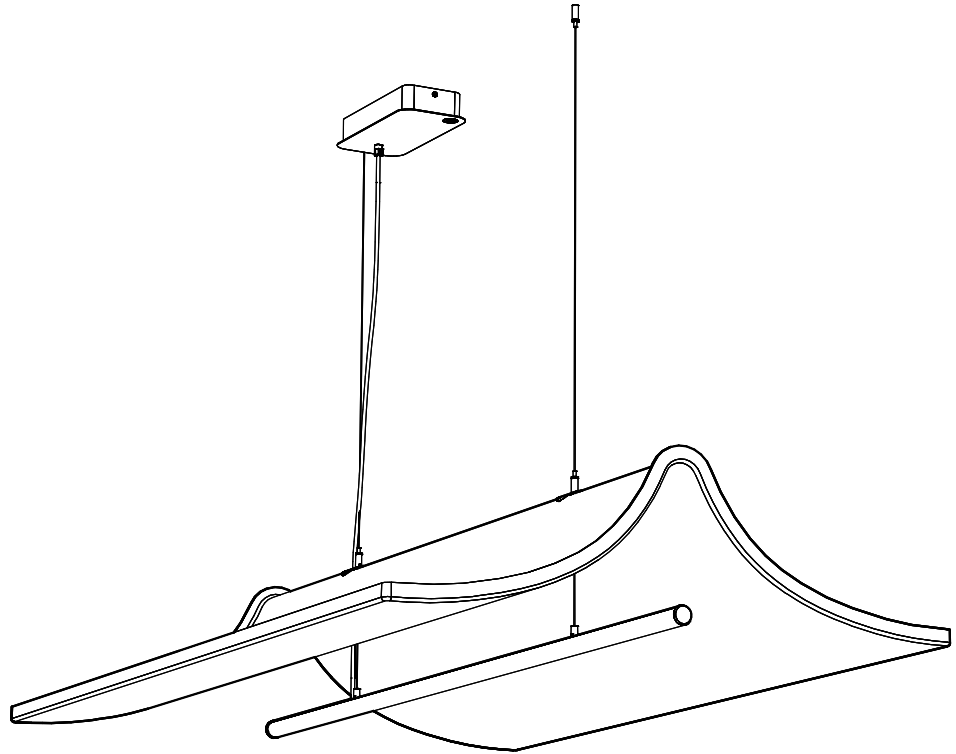

Required order information

1. Lighting Options (Voltage Input, Color Temperature, Dimming, Ceiling Canopy Color)
2. Mounting Option
3. PET Felt Color

Lighting Data

LED Line Glow 140



LED Line Glow 140 is a slim LED profile with a rounded cross-section, designed to provide a wide lighting angle and soft, uniform illumination.

The fixture features a powder-coated black profile finished with a polycarbonate milky diffuser. Its integrated light source consists of two LED strips tailored to the dimensions of LED Line Glow 140, ensuring excellent color consistency and smooth dimming performance. The result is a continuous, uniform light distribution without visible dotting.

BuzziTent Light Lighting options

Lighting Options			Characteristics			Mounting
Voltage Input	Color Temperature	UGR (Diffuser type)	Dimming	Technical	Visual	Options
220-240V	3000K 3500K 4000K	24	0-10V Dali-2	Power consumption: 31W Light output: 4850 Lm Efficacy: 156 Lm/W CRI: > 90	Black or white ceiling canopy Tranparant power cable	2 cables 2 m or 5 m in Alu or Black



Photometric Data

LED Line Glow 140

Cartesian diagram

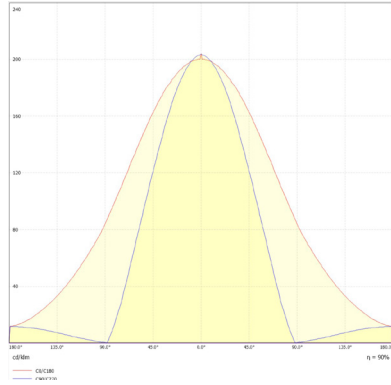

Polar curve

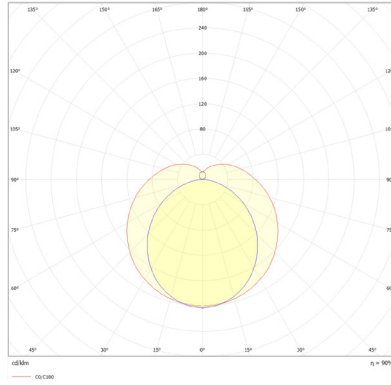

Tips and Tricks - Light Options

To enlight your workplace with optimal lux levels take following measurements into account:

BuzziTent Light

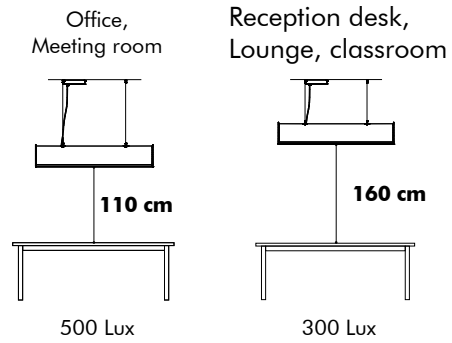

* According to EN12464

Product Data

Fixing System

Ceiling Suspended

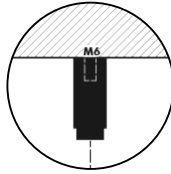
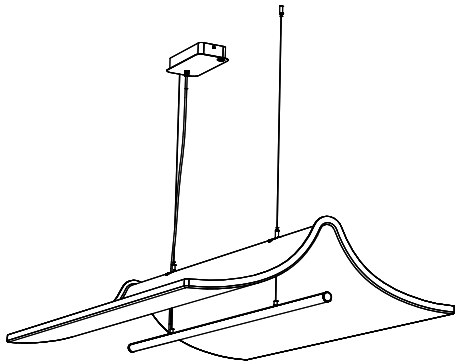

2 cables
2 m or 5 m
Black or Alu
Minimum distance of acoustic panel from ceiling
is 10 cm

Black
Designer's choice

Alu



⚠ If installing on suspended ceiling, verify load capacity prior to installation.

Acoustic Panel



Acoustic Panel in PET Felt



Absorption



Mid tone



High tone

Canopy and power cable



Ceiling canopy is available in two finishes powder-coated black (RAL 9005) or white (RAL 9010).

Power cable is transparent.

Ridge Connector (Optional)



Ridge Connector in black (RAL 9005)
It allows to link multiple BuzziTent (incl. Deco Ridge)
and BuzziTent Light models to create a continuous
configuration.

1 Ridge Connector = linking 2 models of BuzziTent
(incl. Deco Ridge) and/or BuzziTent Light

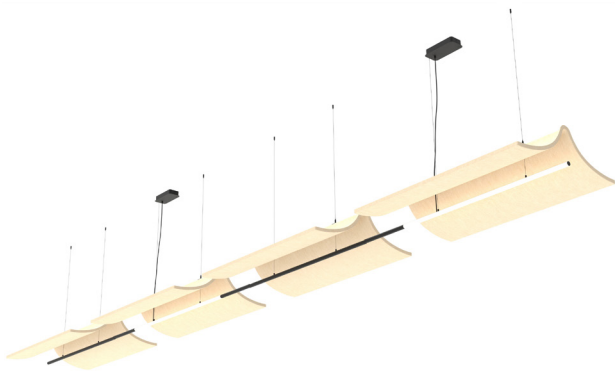

Dimensions

BuzziTent Light

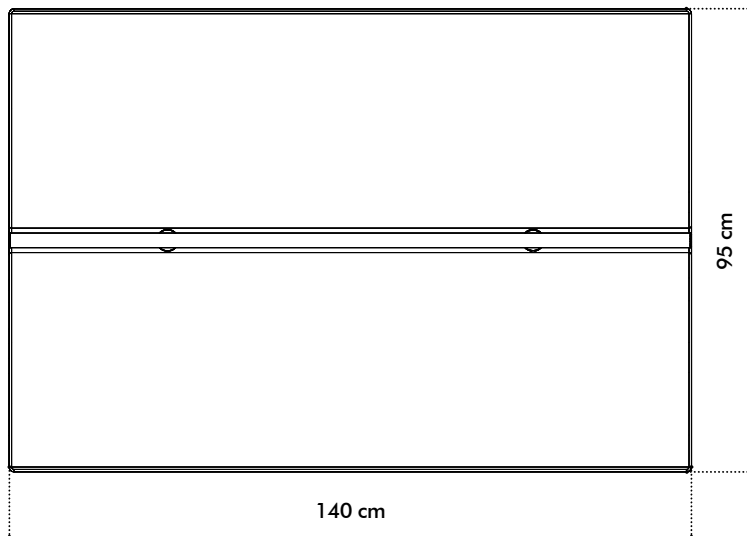
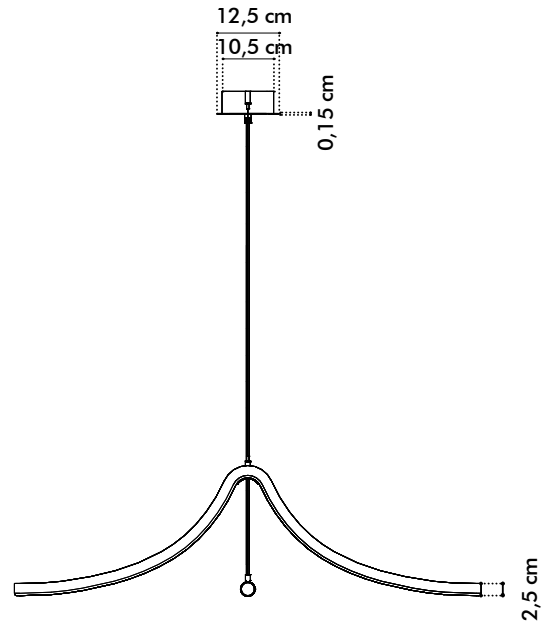
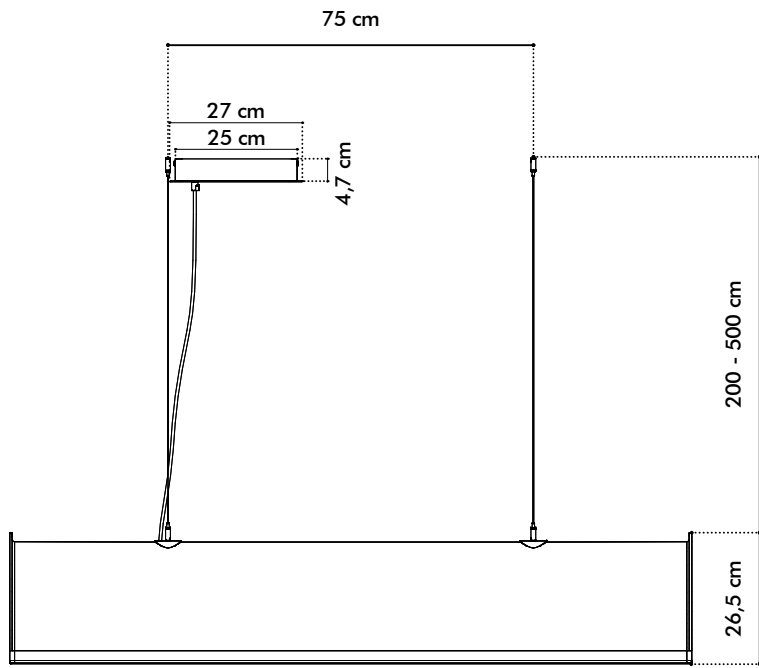

BuzziRidge Connector

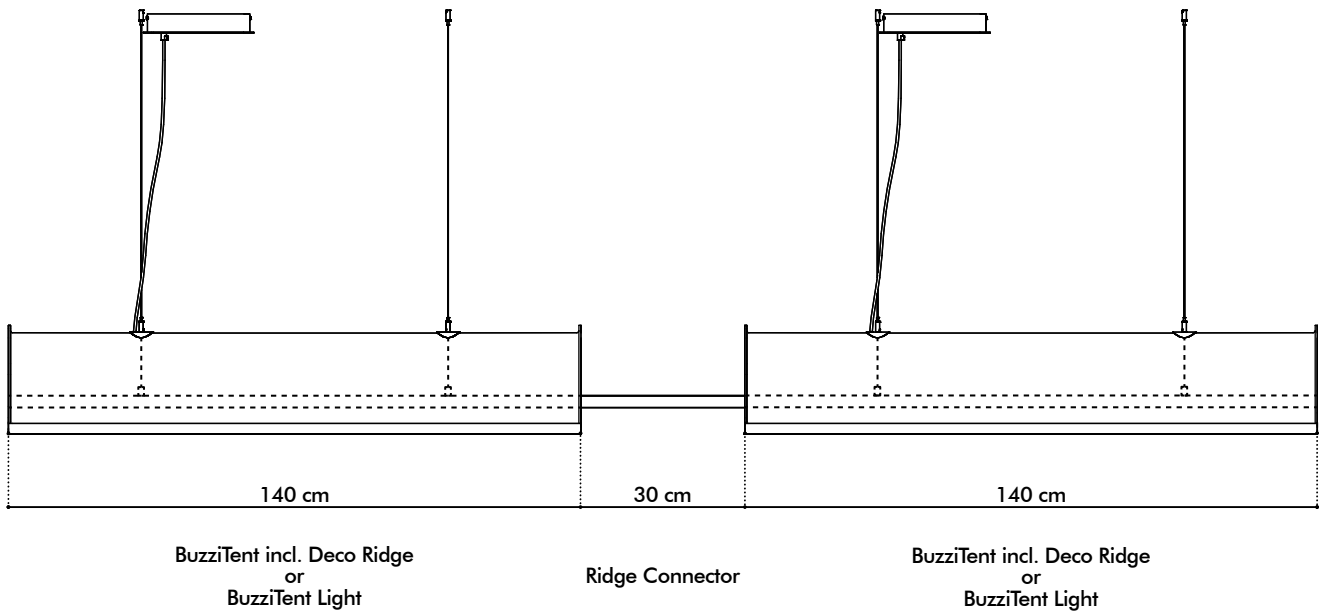
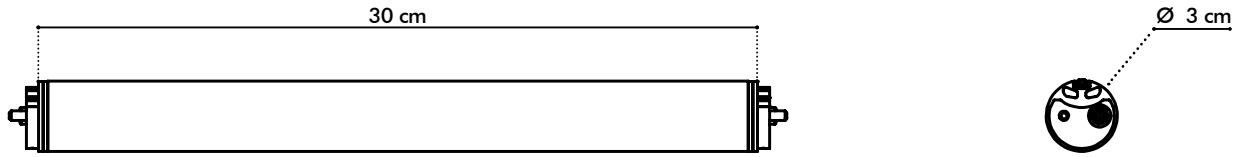

Weights

BuzziTent Light

 7,6 kg

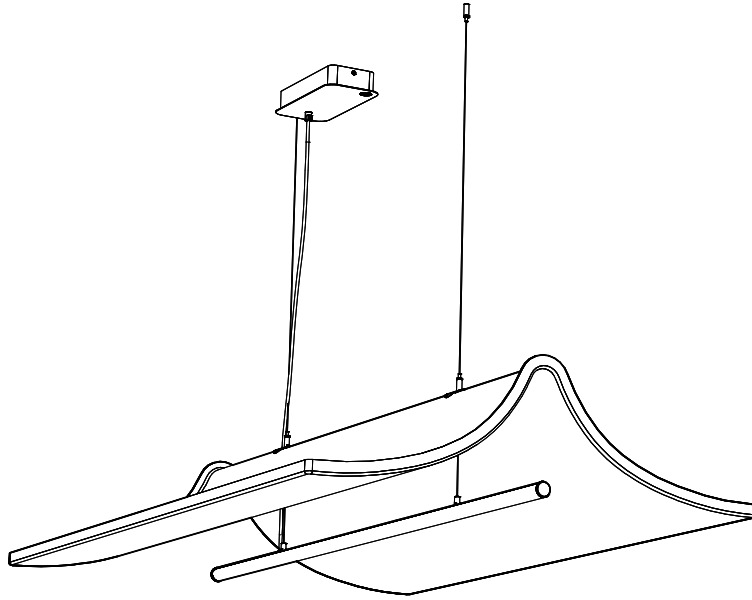

Fabrics

PET Felt

Composition 60% Recycled PET Felt

Weight 2.300 g/m² | 67.8 oz/yd²

Thickness 7 mm | 0.28"

Maintenance For dust removal light vacuuming with a soft nozzle is recommended on a regular basis. For stain removal, patch test on a concealed section first. Spot clean according to the industry standards.

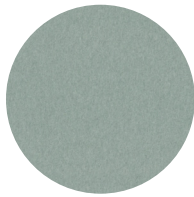

Sage 20

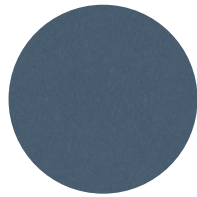

Slate 32

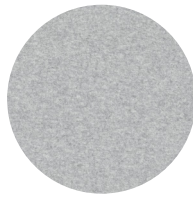

Frost 58



Cream 63

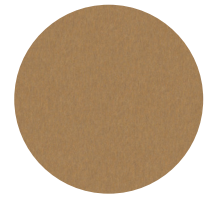

Ochre 65

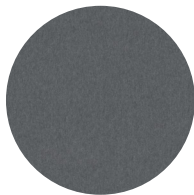

Smoke 71