

## WH AT Adjustable Trolley

Manufactured in accordance with BS EN13155: 2003 + A2: 2009 - Cranes - Safety – Non Fixed Load Lifting Attachments.

The William Hackett WH AT Corrosion Protected Push Trolleys meet and exceed the requirements of the following international standards: British Standard BS EN 13157:2004 + A1:2009.

The WH AT Adjustable Push Trolley features a light weight robust construction, allowing quick and effective installation onto various beams and girders.

The adjustable trolley is fitted with wheel guard anti-drop plates and precision ball bearing wheels allowing easy movement along the beam. It adapts to the beam width by turning the adjustable bar and is fitted with a locking mechanism for ensuring secure clamping to the beam.

W.L.L. capacities of 2.0 tonnes, 3.2 tonnes and 6.0 tonnes are available and the trolleys are designed to accommodate a range of beam widths.



## Specifications

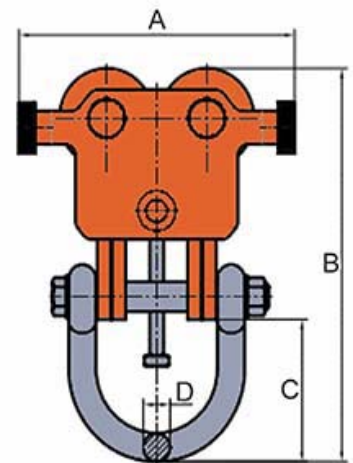
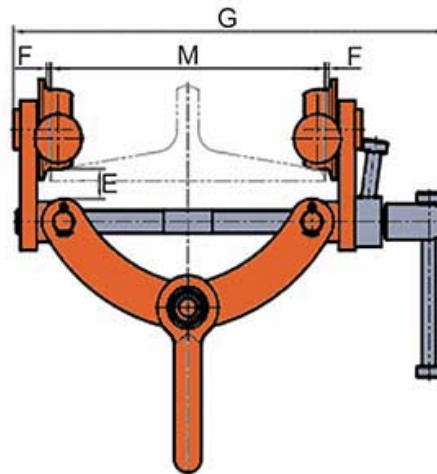

Part Code	WLL tonnes	Min. Radius of Curve m	A mm	B mm	C mm	D mm	E mm	F mm	G mm	Beam Width mm	Mass kg
014.200	2.00	0.7	204	276-322	100	20	21	2.5	320	76-203	8.10
014.320	3.20	1.1	246	334-374	111	20	25	2.5	330	76-203	14.25
014.600	6.00	1.4	286	384-463	124	25	33	3.0	454	100-305	27.40