

Yoke Eye + Eye Angular Swivel

- Yoke Angular Swivels are manufactured using the highest grade of material available.
- They are zinc plated for corrosion resistance and longer life. Angular Swivels are designed for low starting torque and high rotation speed, they are manufactured with grease fittings for superior performance.
- All Angular Swivels are 100% magnaflux crack detected. Designed with a safety factor 5:1.

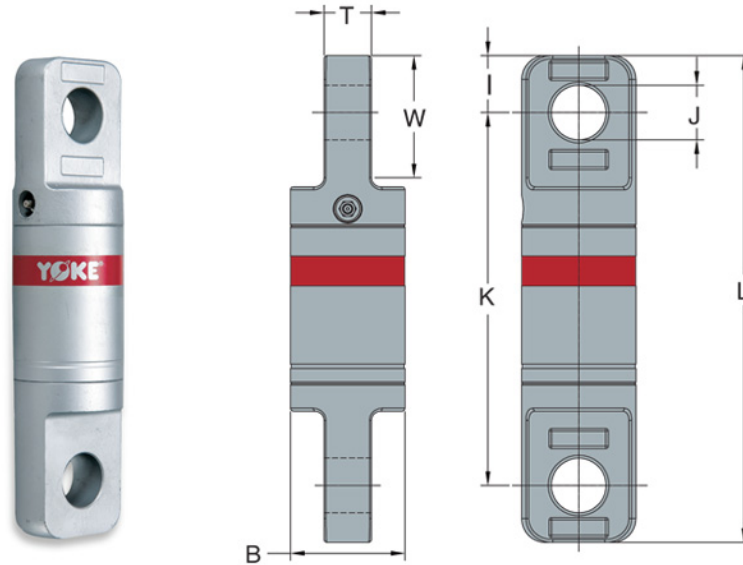

SPECIFICATIONS - Metric

Part Code	Wire Line Size mm	WLL tonnes	B mm	I mm	J mm	K mm	L mm	T mm	W mm	Mass kg
8-306-0075	6	0.75	32	18	19	103	139	12	37	0.5
8-306-015	10	1.5	40	22	23	117	160	15	43	0.9
8-306-03	13	3.0	51	28	27	158	214	20	51	2.1
8-306-05	16	5.0	64	33	33	210	276	26	59	4.4
8-306-085	19	8.5	76	38	37	249	325	32	82	7.3
8-306-10	22	10.0	102	52	44	310	413	42	90	17.0
8-306-15	25	15.0	108	64	54	316	443	49	110	21.0
8-306-25	32	25.0	132	70	66	407	547	60	130	39.0

SPECIFICATIONS - Imperial

Part Code	Wire Line Size inch	WLL tonnes	B inch	I inch	J inch	K inch	L inch	T inch	W inch	Mass lbs.
8-306-0075	1/4	0.75	1.30	0.70	0.70	4.10	5.50	0.50	1.50	1.1
8-306-015	3/8	1.5	1.60	0.90	0.90	4.60	6.30	0.60	1.70	2.0
8-306-03	1/2	3.0	2.00	1.10	1.10	6.20	8.40	0.80	2.00	4.6
8-306-05	5/8	5.0	2.50	1.30	1.30	8.30	10.90	1.00	2.30	9.7
8-306-085	3/4	8.5	3.00	1.50	1.50	9.80	12.80	1.30	3.20	16.1
8-306-10	7/8	10.0	4.00	2.10	2.00	12.20	16.30	1.70	3.50	37.4
8-306-15	1	15.0	4.30	2.50	2.50	12.40	17.40	1.90	4.30	46.3
8-306-25	1-1/4	25.0	5.20	2.80	2.80	16.00	21.50	2.40	5.10	86.00