

Yoke Grade 8 Excavator Weld-on Hook BS EN 1677-1

- Manufactured from forged alloy steel, quenched and tempered.
- Manufactured and tested in accordance with EN1677-1.
- Certified by DGUV GS-OA-15-03.
- Load rated parts are 100% magnaflux crack detected.
- Individual forged parts are traceable to Test Certification.
- Proof tested to 2.5 times the WLL.
- Fatigue rated to 1.5 times the WLL.
- Design Factor 5 : 1

USES

- Designed to be a permanent slinging attachment point for jibs and arms on mobile excavators

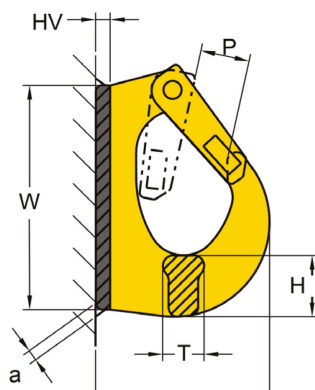

METRIC SPECIFICATIONS

Part Code	WLL tonnes	F mm	H mm	L mm	P mm	T mm	W mm	HV mm	a mm	Box Quantity	Mass Kg
8-081-01	1.0	25	27	70	18	18	95	7	4	24	0.6
8-081-02	2.0	30	30	85	25	20	115	8	5	18	1.0
8-081-03	3.0	35	30	107	28	23	133	9	6	12	1.4
8-081-04	4.0	42	38	114	28	30	142	10	7	12	2.2
8-081-05	5.0	44	47	135	30	31	167	12	7	6	3.0
8-081-08	8.0	50	52	137	32	39	176	12	8	6	3.7
8-081-10	10.0	56	56	170	44	42	222	13	8	4	6.2

IMPERIAL SPECIFICATIONS

Part Code	WLL lbs	F inch	H inch	L inch	P inch	T inch	W inch	HV inch	a inch	Box Quantity	Mass lbs
8-081-01	2,200	0.98	1.06	2.83	0.71	0.67	3.74	0.28	0.24	24	1.3
8-081-02	4,400	1.18	1.22	3.46	0.98	0.79	4.53	0.31	0.31	18	2.2
8-081-03	6,600	1.38	1.18	4.21	1.1	0.91	5.24	0.35	0.39	12	3.1
8-081-04	8,800	1.65	1.5	4.41	1.1	1.18	5.55	0.39	0.43	12	4.4
8-081-05	11,000	1.73	1.81	5.24	1.18	1.22	6.57	0.47	0.51	6	6.6
8-081-08	17,600	1.97	2.13	5.39	1.26	1.54	6.89	0.47	0.55	6	8.4
8-081-10	22,000	2.2	2.2	6.61	1.73	1.65	8.74	0.51	0.63	4	13.9

We recommend that the working load limit should be reduced to meet any appropriate legislative requirements, if welding on to an excavator.

Click here to view video of Yoke Load Attachment Products <http://www.yoke.net/video/en.asp>